

CATALOGO 2025

VERANDE - TENDE - TENDE CUCINA - GAZEBO - SEDIE E TAVOLI - MOBILETTI - ACCESSORI - VERANDE AUTOCARAVAN - ACCESSORI VERANDE E CARAVAN



30+ anni al servizio del campeggiatore

dal 1991...

La pluriennale esperienza maturata nel settore del campeggio permette a CON.VER di offrirvi ogni anno prodotti innovativi e di alta qualità, che garantiscono il massimo comfort per le vostre vacanze.

È ormai da più di trent'anni, infatti, che il nostro staff si impegna ad introdurre sul mercato prodotti di qualità, ottenuti prestando la massima cura al design ed alla scelta dei materiali.

L'elevato standard qualitativo dei processi di produzione, unitamente all'avanzato grado tecnologico degli impianti, consentono a CON.VER di ideare e creare, negli stabilimenti di Codogno, prodotti che prendono in considerazione le esigenze e le aspettative di un mercato in continua evoluzione.

La qualità dei nostri prodotti è data dalla cura e dall'attenzione che da sempre riponiamo, in prima persona, nel nostro lavoro, permettendoci di soddisfare al meglio anche le richieste del campeggiatore più esigente.

Sfogliando il nostro nuovo catalogo avrete modo di entrare nel mondo del campeggio CON.VER e di scegliere gli articoli più adatti alle vostre vacanze.

SINCE 1991...

The multi-year experience gained in the camping sector allows CON.VER to offer innovative and high-quality products every year, ensuring the maximum comfort for your holidays.

For more than thirty years, in fact, our staff has been committed to introducing to the market quality products, obtained by paying the utmost attention to design and choice of materials.

The high-quality standard of the production processes, together with the advanced technological level of the plants, allows CON.VER to design and create, at the Codogno headquarter, products that take into consideration the needs and expectations of a constantly evolving market.

The quality of our products is given by the care and attention that we have always personally placed in our work, allowing us to best satisfy even the most demanding campers' requests.

By leaf through our new catalogue, you will have the opportunity to enter the world of CON.VER and to choose the most suitable items for your holidays.



LA VERANDA GIUSTA

Grazie ai molti anni di esperienza nel settore, **CON.VER** è in grado di proporre una vasta gamma di verande adatta alle esigenze di qualsiasi campeggiatore. Consigliamo di prestare molta attenzione alle caratteristiche dei modelli al fine di individuare la veranda più idonea al tipo di campeggio praticato. Materiali differenti vengono impiegati per camping itinerante o stanziale, camping marittimo o montano, i nostri rivenditori sono a disposizione per consigliarvi nella scelta e trarre piena soddisfazione dal prodotto da voi acquistato.

LA TAGLIA GIUSTA

Per determinare in modo corretto la taglia della veranda, è necessario posizionare la caravan su un terreno pianeggiante e misurare il suo sviluppo perimetrale da "terra a terra", seguendo il profilo in alluminio. Nel caso in cui si utilizzi un pavimento rialzato all'interno della veranda, è necessario portare la caravan alla stessa quota del pavimento, misurare quindi lo sviluppo della caravan da "pavimento a pavimento", fissare quindi la veranda sullo stesso. Lo sviluppo perimetrale (A-B), la misura dell'architrave a livello della finestra (C-D) e quella dell'architrave a metà caravan (E-F), sono dati necessari per individuare in modo corretto la taglia della veranda. In ogni caso, è consigliabile rivolgersi ad un rivenditore autorizzato per avere informazioni più precise circa l'esattezza della taglia stessa.

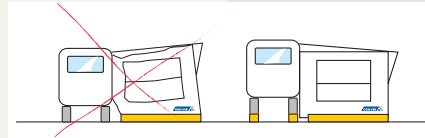

THE RIGHT AWNING

Thanks to many years' experience in the sector of camping, **CON.VER** is able to offer a wide range of awnings suitable for any camper's requirements. Different materials are used for travelling or resident camping; our dealers are at disposal to guide you to make the right choice in order to get the best from the purchased item.

THE RIGHT AWNING

In order to find the correct size of the awning, it is necessary to place the caravan on a flat ground and measure its perimeter "ground-to-ground" by following the aluminium profile. If there is a raised floor inside the awning, it is necessary to bring the caravan to the same level of the floor and then measure the caravan perimeter "floor-to-floor" and fix the awning to the floor itself. The perimeter (A-B), the measure of the lintel (C-D) and the measure in the middle of the caravan ((E-F), are fundamental to correctly define the size of the awning. We suggest contacting an authorized dealer to receive more precise information about the correctness of the chosen size.

LE VERANDE

E' per noi motivo d'orgoglio presentarvi la nostra collezione di verande. Si tratta, sicuramente, dell'articolo più prestigioso che possiamo offrire nel settore e che ci ha permesso di diventare una delle aziende leader del mercato. Ogni nostro modello viene creato utilizzando tessuti di alta qualità forniti da aziende leader nel settore. Le palerie, in alluminio, sono costruite interamente nella nostra officina che è anche in grado di fornire piena assistenza sui ricambi e sugli accessori. Le nostre verande sono studiate e create nei nostri stabilimenti di Codogno, rispettando quell'originalità e quella creatività che da sempre contraddistinguono la produzione "Made in Italy", apprezzata in tutto il mondo.

AWNING

We are proud to show you our collection of awnings. It is certainly our most prestigious item, which has allowed us to become one of the leading companies of this market. The materials employed for every single model have been carefully chosen from very important companies. Aluminium poles kit are made in our workshop, therefore we assure our assistance on the spares and fittings. Our awnings are entirely produced in our factory in Codogno, we offer you a product "Made in Italy", with those characteristics of originality and creativity appreciated all over the world.

I PUNTI DI FORZA DELLE NOSTRE VERANDE

Oltre alla qualità dei materiali utilizzati ed alla scrupolosa cura con cui vengono scelti ed abbinati i colori dei tessuti, le verande Con.ver si distinguono per una serie di caratteristiche che le rendono uniche ed inimitabili:

- Paleria in alluminio telescopica
- Snodi in acciaio tropicalizzato
- Pali di rinforzo sul verandino
- Oscurante con cerniera
- Cavetto termosaldato (esclusiva Con.ver)
- Zanzariere di aerazione
- Ancoraggi antivento
- Ancorette portaelastico
- Tessuti resinati
- Balza in PVC
- Triangolo di compensazione: permette di adattare la veranda a caravan particolarmente aerodinamiche
- Migliore vestibilità (20 cm tra una taglia e la successiva)

AWNING: TECHNICAL FEATURES

Con.ver's awnings are characterized by the high quality of the materials employed, the scrupulous care in the colour coupling and a special range of technical features, as follows, that make them unique and inimitable

- Telescopic aluminium pole kit
- Galvanized steel cross
- Reinforcing poles on the casquette
- Zipped darkening cover
- Heated seal rubber-coated cable (Con.ver exclusive)
- Ventilation mosquito-net
- Anchorage
- Hooks for rubber band
- Resin-coated fabrics
- Double coated mudwall
- Compensation triangle (aerodynamic caravan)
- Better size options, great fit (20 cm between one size and the other)

TRASPORTI

La merce è resa franco nostro magazzino.

La merce viaggia a rischio e pericolo del cliente, **CON.VER** non è responsabile di eventuali danni. Il cliente, al momento della consegna, è tenuto a controllare il contenuto degli imballi e lo stato della merce, accettandola se necessario "con riserva".

Eventuali danni o ammanchi devono essere subito reclamati al vettore e segnalati sul documento di spedizione; copia di tale documento dovrà essere inviata per conoscenza a CON.VER.

L'inadempimento della verifica libera CON.VER da ogni responsabilità.

TRANSPORTS

Goods are delivered ex-works and moved at customer's risk. **CON.VER** is not responsible for any damages or losses. On receipt of goods, the customer should inspect the packaging and the conditions of goods. If necessary, the customer can accept them as "received unchecked".

Any damages or deficiencies shall be immediately claimed to the carrier and reported on the shipment document. A copy of such document shall be sent CON.VER. The non-performance of the check, releases CON.VER from any responsibility.

PAGAMENTI

Da concordare in fase di ordinazione.

PAYMENTS

To be agreed when the order is placed

GARANZIA

Ogni articolo **CON.VER** è studiato nei minimi particolari e realizzato con materiali che garantiscono un prodotto di altissima qualità. In caso di anomalie sui nostri articoli è possibile usufruire della garanzia di 2 anni dalla data di acquisto. Importante ricordare che **la garanzia COPRE solo ed esclusivamente i difetti di fabbricazione.**

Gli articoli che si ritiene abbiano un difetto di fabbricazione non devono essere utilizzati in alcun modo, l'utilizzo, anche solo parziale, fa decadere ogni diritto a godere della garanzia. La garanzia NON COPRE i danni causati da:

- Incidenti, negligenza, manutenzione inadeguata, errato montaggio.
 - Utilizzo improprio o dovuto alla normale usura.
 - Danni causati dal trasporto (trascinamento, caduta accidentale, scondizionamento imballo).
 - Eventuali infiltrazioni d'acqua attraverso le cerniere e le cuciture in seguito a temporali con forti venti.
- Gli eventuali prodotti difettosi devono essere resi a **CON.VER** previa autorizzazione con spedizione a carico del cliente. Importante ricordare che la merce deve essere imballata con cura.

CON.VER provvederà a sostituire o riparare, a sua discrezione, il prodotto per il quale è stato chiesto l'intervento in garanzia. Qualora il difetto non sia coperto da garanzia, **CON.VER** eseguirà la riparazione addebitandola al costo.

WARRANTY

Each **CON.VER** item is designed in the smallest detail and manufactured with high quality materials. Each item is covered by a 2 year guarantee from the purchase date if it turns out to be faulty. It is important to remember that **the warranty COVERS manufacturing defects only**

If the goods are deemed defective, they should not be used in any way; the use, even if partial, rules out any manufacturer's warranty. The warranty does NOT COVER damages due to:

- Accidents, negligence, improper handling, wrong assembly.
 - Damages due to transport (pulling, accidental fall, packaging unwrapped).
 - Any water seepage through the zippers and seams as a result of unfavourable weather conditions.
- Faulty items shall be sent back to CON.VER upon prior Company authorization. Transport costs are charged to the customer. It is very important that goods are accurately packed. **CON.VER** will replace or repair the product involved in the claim for warranty at its own discretion. If the item should not be covered by the warranty, **CON.VER** will repair it at the customer's expense.

RIPARAZIONI

Le riparazioni vengono eseguite solo ed esclusivamente nei periodi di bassa stagione (Ottobre - Gennaio).

I prodotti da riparare devono essere inviati a **CON.VER PULITI ED IMBALLATI CON CURA**, accompagnati dalla descrizione dei lavori da eseguire.

Il materiale non pulito verrà rispedito senza effettuare nessun intervento. Importante ricordare che **CON.VER** esegue interventi solo sui propri prodotti.

REPAIRS

Repairs are carried out only and exclusively in the low season periods (October-January). The items that need to be repaired have to be shipped to **CON.VER, CAREFULLY CLEANED AND PACKED**, by including the description of the works to be carried out.

Not suitable clean items will be sent back without any repair. It is important to know that CON.VER repairs its own products only.

SOSTITUZIONI

CON.VER non accetta richiesta di sostituzione per taglia errata o modello differente. In casi eccezionali e comunque preventivamente concordati è possibile chiedere la sostituzione del prodotto inviandolo a spese del cliente a **CON.VER** per la verifica di integrità e pulizia. Se idoneo al ritiro **CON.VER** spedisce il nuovo prodotto emettendo nota di credito per il reso. Qualora il reso non verrà ritenuto idoneo al ritiro verrà rispedito al cliente.

REPLACEMENTS

CON.VER does not accept any replacement claim due to wrong size or different model. In extraordinary cases and however previously agreed, the customer may ask to replace the product by sending it to **CON.VER** at his/her own costs, in order to check integrity and cleaning. If the product is eligible for collection **CON.VER** will send the new product by issuing a credit note for the returned item. In the event that the returned item will not be considered eligible for the collection, it will be sent back to the customer.



COME SCEGLIERE LA TENDA VERANDA GIUSTA

HOW TO CHOOSE THE RIGHT AWNING

linea PROMO

Verande adatte ad essere utilizzate per periodi di breve durata.
Awnings for a short period use.



linea CLASSIC

Verande per chi ama il campeggio stanziale, adatte per essere montate per un lungo periodo.
Awnings for those who love residence camping suitable for being installed for a long term period.

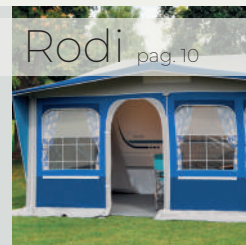

NEW product

NEW product

NEW product

I SUGGERIMENTI DI CON.VER SUGGESTIONS FROM CON.VER

STAI CERCANDO UNA VERANDA PER UNA BREVE VACANZA? CHIA È LA SOLUZIONE PER TE, GRAZIE ALLE SUE CARATTERISTICHE E L'OTTIMALE RAPPORTO QUALITÀ PREZZO.

ARE YOU LOOKING FOR AN AWNING FOR A SHORT VACATION? CHIA IS THE SOLUTION FOR YOU, THANKS TO ITS FEATURES AND THE OPTIMAL QUALITY/PRICE RATIO.

FAI CAMPEGGIO STANZIALE ED HAI L'ESIGENZA DI VARIARE LA CONFIGURAZIONE DELLA TUA VERANDA? SUGGERIAMO SAHARA, POICHÉ L'INTERCAMBIABILITÀ DEI SUOI PANNELLI NE FANNO LA VERANDA PIÙ VERSATILE SUL MERCATO.

ARE YOU FOND OF RESIDENCE CAMPING AND DO YOU NEED TO CHANGE YOUR AWNING CONFIGURATION? WE RECOMMEND SAHARA, BECAUSE THE INTERCHANGEABILITY OF ITS PANELS MAKES IT THE MOST VERSATILE VERANDA ON THE MARKET.

spesso acquistato in abbinamento a
Cucina
often purchased with
Kitchen



Tappeto
Carpet



Parasole
Sunshade



VERANDE

linea PROMO

Aspen



Aspen



CARATTERISTICHE TECNICHE

- Profondità della veranda: cm 250 più verandino di cm 50
- Pareti laterali amovibili con finestra in zanzariera e coprifestra incernierati.
- Facciata con doppio ingresso e finestre in cristallo trasparente: dalla taglia 5 alla 11, due finestre; dalla taglia 12 alla 15, quattro finestre.
- Fascia copri ruota inclusa.
- Grondine di protezione sulle cerniere esposte all'acqua.
- Paleria in alluminio a regolazione globale: la taglia 5 con tre pali al tetto, dalla taglia 6 fino alla 11, cinque pali al tetto, dalla taglia 12 alla 15, sette pali al tetto e cinque verticali.

NB: Fantasia tessuto tendine secondo disponibilità

OPTIONALS:

- Cucina di larghezza cm 200 e profondità cm 130

TECHNICAL FEATURES:

- Awning's depth cm 250 and casquette cm 50
- Removable side panels with mosquito net windows and zippered cover.
- Double entrances facade with crystal windows: two windows from 5th to 11th size, four windows from 12th to 15th size.
- PVC wheel cover included.
- Protective gutter upon the zips exposed to the water.
- Aluminium pole kit with total regulation: size 5th three poles at the roof, from 6th to 11th size, five poles at the roof, from 12th to 15th, seven poles at the roof and five vertical poles.

NB: Fantasy fabric curtains to availability.

OPTIONALS:

- Kitchen: breadth cm 200 and depth cm 130



SVILUPPO	TAGLIA
801-820	5
821-840	6
841-860	7
861-880	8
881-900	9
901-920	10
921-940	11
941-960	12
961-980	13
981-1000	14
1001-1020	15
cucina	



taglia 5-11



taglia 12-15



VERANDE

linea PROMO

Chia



Chia



SVILUPPO	TAGLIA
801-820	5
821-840	6
841-860	7
861-880	8
881-900	9
901-920	10
921-940	11
941-960	12
961-980	13
981-1000	14
1001-1020	15
cucina	



taglia 5-12



taglia 13-15

CARATTERISTICHE TECNICHE

- Profondità della veranda: cm 250 più verandino di cm 50
- Pareti laterali amovibili con finestra a 2 strati (zanzariera + cristal quadrettato incernierato) e porta.
- Facciata composta da pannelli amovibili ed intercambiabili con finestre a tre strati (zanzariera + cristal + oscurante). Dalla taglia 5 alla 12 tre finestre, dalla 13 alla 15, quattro finestre.
- Porta frontale dotata di zanzariera..
- Fascia copriuota inclusa.
- Grondine di protezione sulle cerniere esposte all'acqua.
- Ventilazione regolabile sulla facciata..
- Paleria in alluminio a regolazione globale: la taglia 5 con tre pali al tetto, dalla taglia 6 fino alla 11, cinque pali al tetto, dalla taglia 12 alla 15, sette pali al tetto e cinque verticali.

NB: Fantasia tessuto tendine secondo disponibilità

OPTIONALS:

- Cucina di larghezza cm 200 e profondità cm 130

TECHNICAL FEATURES:

- Awning's depth cm 250 and casquette cm 50
- Removable side walls with double layer windows (mosquito net + zipped squared crystal cover) and doors..
- Removable and interchangeable facade with three layers windows (mosquito net + crystal + shade). From 5th to 12th size, three windows, from 13th to 15th size, four windows. · PVC wheel cover included.
- Frontal door with mosquito net..
- PVC wheel cover included.
- Protective gutter upon the zips exposed to the water.
- Adjustable frontal ventilation..
- Aluminium pole kit with total regulation: size 5th three poles at the roof, from 6th to 11th size, five poles at the roof, from 12th to 15th, seven poles at the roof and five vertical poles.

NB: Fantasy fabric curtains to availability.

OPTIONALS:

- Kitchen: breadth cm 200 and depth cm 130

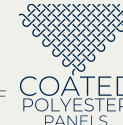





MADE IN ITALY 

Rodi

L'unico modello di veranda della nostra gamma disponibile dalla taglia 1 alla 15. Anche le caravan più piccole possono avere la loro veranda.

The only awning model in our range available from size 1 to 15. Even smaller caravans can have their own awning.

VERANDE

linea CLASSIC



SVILUPPO	TAGLIA
720-740	1
741-770	2
771-790	3
791-820	4
821-840	5
841-860	6
861-880	7
881-900	8
901-920	9
921-940	10
941-960	11
961-980	12
981-1000	13
1001-1020	14
1021-1040	15
cucina	



taglia 1-2



taglia 3



taglia 4-12



taglia 13-15





MADE IN ITALY

CON.VER 

Rodi

CARATTERISTICHE TECNICHE

- Profondità della veranda: cm 250 più verandino di cm 50
 - Cavetto di collegamento termosaldato.
 - Pareti laterali amovibili con finestra in zanzariera e copri finestra incernierato in cristal quadrettato.
 - Facciata composta da pannelli amovibili ed intercambiabili (escluse taglia 1 - 2 - 3) con finestre in crista trasparente e zanzariera. Le taglie 1 e 2 hanno due finestre e porta laterale; la taglia 3 una finestra e porta centrale; dalla taglia 4 alla 12, tre finestre; dalla 13 alla 15, quattro finestre.
 - Fascia copriruota inclusa.
 - Grondine di protezione sulle cerniere esposte all'acqua.
 - Paleria in alluminio a regolazione globale: dalla taglia 1 alla 4, tre pali al tetto, dalla taglia 5 fino alla 10, cinque pali al tetto, dalla taglia 11 alla 15, sette pali al tetto e cinque verticali.
- NB: Fantasia tessuto tendine secondo disponibilità

OPTIONALS:

- Cucina di larghezza cm 200 e profondità cm 130

TECHNICAL FEATURES:

- Awning's depth cm 250 and casquette cm 50
 - Thermo welded connection keder.
 - Removable side walls with mosquito net windows and zipped squared crystal covers.
 - Removable and interchangeable facade (no sizes 1 - 2 - 3) with trasparent crystal and mosquito net windows. Sizes 1 and 2 have two windows and a side door; size 3rd has two windows and a central door; from 4th to 12th, three windows; from 13th to 15th, four windows.
 - PVC wheel cover included.
 - Protective gutter upon the zips exposed to the water.
 - Aluminium pole kit with total regulation: from first to 4th size, three poles at the roof, from 5th to 10th size, five poles at the roof; from 11th to 15th, seven poles at the roof and five vertical poles.
- NB: Curtains fabric pattern to availability.

OPTIONALS:

- Kitchen: breadth cm 200 and depth cm 130

VERANDE
linea CLASSIC

VERANDE
linea CLASSIC





MADE IN ITALY

Maiorca

La particolare conformazione della veranda Maiorca consente di avere le finestre frontali tra le più grandi tra le nostre verande.

Dotata di oscuranti su tutte le finestre consente il completo oscuramento interno.

The particular shape of the Mallorca awning allows you to have the largest front windows among our awnings. Equipped with blinds on all windows provides the complete internal obscuring.



SVILUPPO	TAGLIA
791-820	4
821-840	5
841-860	6
861-880	7
881-900	8
901-920	9
921-940	10
941-960	11
961-980	12
981-1000	13
1001-1020	14
1021-1040	15
cucina	



NEW
product

MADE IN ITALY

CON.VER 

Maiorca

CARATTERISTICHE TECNICHE

- Profondità della veranda: cm 250 più verandino di cm 50
 - Cavetto di collegamento termosaldato.
 - Pareti laterali amovibili con finestra in zanzariera e oscurante incernierato.
 - Facciata amovibile a doppio ingresso con finestre in cristal fumé ed oscuranti incernierati. Due finestre dalla taglia 4 alla 15.
 - Fascia copriruota inclusa.
 - Grondine di protezione sulle cerniere esposte all'acqua.
 - Palaria in alluminio a regolazione globale: La taglia 4 ha tre pali al tetto; dalla taglia 5 alla 10, 5 pali al tetto; dalla taglia 11 alla 15, sette pali al tetto e cinque verticali.
- NB: Fantasia tessuto tendine secondo disponibilità

OPTIONALS:

- Cucina di larghezza cm 200 e profondità cm 130

TECHNICAL FEATURES:

- Awning's depth cm 250 and casquette cm 50
 - Thermo welded connection keder.
 - Removable side walls with mosquito net windows and zipped shades.
 - Removable double entrances facade with smoked crystal windows and zipped shades. From 4th to 15th size, two windows.*
 - PVC wheel cover included.
 - Protective gutter upon the zips exposed to the water.
 - Aluminium pole kit with total regulation: Size 4th has three poles at the roof; from 5th to 10th size, five poles at the roof; from 11th to 15th, seven poles at the roof and five vertical poles.
- NB: Curtains fabric pattern to availability.

OPTIONALS:

- Kitchen: breadth cm 200 and depth cm 130

VERANDE
linea CLASSIC

VERANDE
linea CLASSIC





MADE IN ITALY 

Sahara

Versatilità è la parola che meglio descrive la veranda Sahara. Tutti i pannelli che compongono le pareti sono intercambiabili tra loro. Grazie a questa caratteristica ognuno può configurare la veranda secondo le proprie esigenze.

Versatility is the word that best describes the Sahara awning. All the panels that make up the walls are interchangeable with each other. Thanks to this feature, everyone can configure the awning according to their needs.

VERANDE
linea CLASSIC

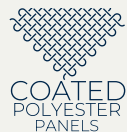

SVILUPPO

SVILUPPO	TAGLIA
841-860	6
861-880	7
881-900	8
901-920	9
921-940	10
941-960	11
961-980	12
981-1000	13
1001-1020	14
1021-1040	15
cucina	
kit pali per montaggio cucina frontale	



taglia 6-15



MADE IN ITALY

CON.VER  *Tende*

Sahara

CARATTERISTICHE TECNICHE

- Profondità della veranda: cm 250 più verandino di cm 50
 - Cavetto di collegamento termosaldato.
 - Ciascuna veranda è composta da 4 pannelli completamente intercambiabili tra loro (2 con porta e finestra e 2 con finestra).
 - Tutte le finestre sono a tre strati: zanzariera + cristal incernierato + oscurante incernierato.
 - Fascia copriruota inclusa.
 - Grondine di protezione sulle cerniere esposte all'acqua
 - Palaria in alluminio a regolazione globale: dalla taglia 6 alla 10, cinque pali al tetto; dalla taglia 11 alla 15, sette pali al tetto e cinque verticali.
- NB: Fantasia tessuto tendine secondo disponibilità

OPTIONALS:

- Cucina di larghezza cm 200 e profondità cm 130

TECHNICAL FEATURES:

- Awning's depth cm 250 and casquette cm 50
 - Thermo welded connection keder.
 - Each awning consists of 4 panels completely interchangeable (2 with door and window and 2 with window).
 - All the windows have three layers: mosquito net + zipped crystal + zipped shade.
 - PVC wheel cover included.
 - Protective gutter upon the zips exposed to the water.
 - Aluminium pole kit with total regulation: from 6th to 10th size, five poles at the roof; from 11th to 15th, seven poles at the roof and five vertical poles.
- NB: Curtains fabric pattern to availability.

OPTIONALS:

- Kitchen: breadth cm 200 and depth cm 130

VERANDE
linea CLASSIC

VERANDE
linea CLASSIC



NEW
product

CON.VER  *Tente*



MADE IN ITALY

Cortina

La veranda giusta per chi sta cercando un prodotto interamente in pvc.

Particolarmente indicata a chi ama il campeggio invernale ed in aree montane ma non vuole rinunciare al comfort.

The right awning for those who are looking for a whole PVC item. Particularly suitable for those who love winter camping, even in mountain areas but do not want to give up comfort.

VERANDE
linea CLASSIC



SVILUPPO	TAGLIA
841-860	5
841-860	6
861-880	7
881-900	8
901-920	9
921-940	10
941-960	11
961-980	12
981-1000	13
1001-1020	14
1021-1040	15
cucina	



taglia 5-15



NEW
product

MADE IN ITALY

CON.VER 

Cortina

CARATTERISTICHE TECNICHE

- Profondità della veranda: cm 250 più verandino di cm 50
 - Cavetto di collegamento termosaldato.
 - Pareti laterali amovibili con finestra a tre strati: oscurante incernierato + zanzariera + cristal fumè incernierato.
 - Facciata composta da pannelli amovibili con finestre a tre strati: oscurante incernierato + zanzariera + cristal fumè incernierato. Dalla taglia 5 alla 15 tre finestre e porta centrale.
 - Fascia copriruota inclusa.
 - Palaria in alluminio a regolazione globale: dalla taglia 5 alla 10, cinque pali al tetto; dalla taglia 11 alla 15, sette pali al tetto e cinque verticali.
- NB: Fantasia tessuto tendine secondo disponibilità

OPTIONALS:

- Cucina di larghezza cm 200 e profondità cm 130

TECHNICAL FEATURES:

- Awning's depth cm 250 and casquette cm 50
 - Thermo welded connection keder.
 - Removable side walls with three layers windows: zipped shade + mosquito net + zipped smoked crystal.
 - Removable facade with three layers windows: zipped shade + mosquito net + zipped smoked crystal. From 5th to 15th size, three windows and a central door.
 - PVC wheel cover included.
 - Aluminium pole kit with total regulation: from 5th to 10th size, five poles at the roof; from 11th to 15th, seven poles at the roof and five vertical poles.
- NB: Curtains fabric pattern to availability.

OPTIONALS:

- Kitchen: breadth cm 200 and depth cm 130

VERANDE
linea CLASSIC

VERANDE
linea CLASSIC



NEW
product

CON.VER 



MADE IN ITALY

Milos

Per chi avesse la necessità di una veranda che si adatti a piazzole più piccole del solito. La profondità di 2,30m e l'assenza del verandino frontale permettono a questa veranda di occupare meno spazio rispetto agli altri modelli.

For those who need an awning that fits smaller campsites than usual.

The depth of 2.30m and the absence of the front veranda allow this awning to take up less space than the other models.

VERANDE
linea CLASSIC

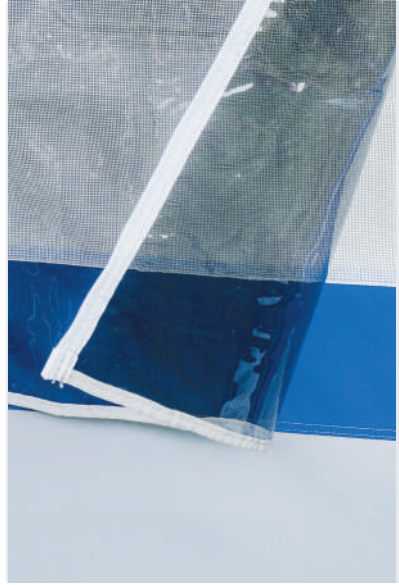
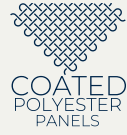

SVILUPPO	TAGLIA
841-860	6
861-880	7
881-900	8
901-920	9
921-940	10
941-960	11
961-980	12
981-1000	13
cucina	



taglia 6-9



taglia 10-13



NEW
product

MADE IN ITALY

CON.VER 

Milos

CARATTERISTICHE TECNICHE

- Profondità della veranda: cm 230, senza verandino.
- Cavetto di collegamento termosaldato.
- Possibilità di applicare il parasole sulla facciata frontale con il cavetto keder (profondità parasole 200 cm)
- Pareti laterali amovibili con finestra a due strati: zanzariera + cristallo fumè incernierato.
- Facciata composta da pannelli amovibili con finestre a due strati: zanzariera + cristallo fumè incernierato. Dalla taglia 6 alla 9 due finestre e porta centrale. Dalla taglia 10 alla 13 tre finestre e porta centrale.
- Fascia copriruota inclusa.
- Palaria in alluminio a regolazione globale: dalla taglia 6 alla 10, cinque pali al tetto; dalla taglia 11 alla 13, sette pali al tetto e cinque verticali.

OPTIONALS:

- Tendina per finestra. (Fantasia tessuto tendine secondo disponibilità.)
- Cucina di larghezza cm 200 e profondità cm 130

TECHNICAL FEATURES:

- Awning's depth cm 230, without casquette.
- Thermo welded connection keder.
- A sunshade can be connected with keder on the front (sunshade depth 200 cm)
- Removable side walls with two layers windows: mosquito net + zipped smoked crystal.
- Removable facade with two layers windows: mosquito net + zipped smoked crystal. From 6th to 9th size, two windows and a central door. From 10th to 13th size, three windows and a central door.
- PVC wheel cover included.
- Aluminium pole kit with total regulation: from 6th to 10th size, five poles at the roof; from 11th to 13th, seven poles at the roof and five vertical poles.

OPTIONALS:

- Window curtains (curtains fabric pattern to availability.)
- Kitchen: breadth cm 200 and depth cm 130

PREDISPOSIZIONE per applicazione
PARASOLE INTEGRATA

INTEGRATED system for
SUNSHADE APPLICATION



VERANDE
linea CLASSIC

VERANDE

linea CLASSIC

MADE IN ITALY

Creta



Creta

CARATTERISTICHE TECNICHE

"CRETA" è un tendalino parasole realizzato in tessuto poliestere 100%. La particolarità del materiale utilizzato garantisce una buona resistenza all'usura nel tempo. È un accessorio ideale per il "caravanning" itinerante grazie alla praticità d'impiego.

- Profondità cm 240

OPTIONALS:

- Pareti laterali (vedi foto).

TECHNICAL FEATURES:

"CRETA" is a small sunshade tent realized in polyester 100%. The superlative quality of fabrics guarantees good resistance against ageing. It is an essential accessory in itinerant caravanning, for extremely practical.

- Depth cm 240

OPTIONALS:

- Sidewalls (see picture).



SVILUPPO

320-350

TAGLIA

1

350-400

2

400-440

3

440-480

4

480-520

5

520-560

6

Parete laterale

taglia 1-6

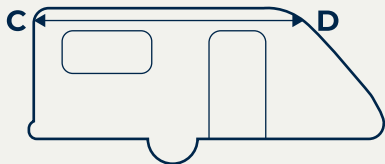

Per determinare la taglia del parasole, rilevare la misura C-D come illustrato nel disegno e confrontarla con i dati riportati nella tabella sopra.



VERANDE

linea CLASSIC

MADE IN ITALY

Solar



Solar

CARATTERISTICHE TECNICHE

Tendalino parasole ideale per il campeggio itinerante. Per un ulteriore comfort il tendalino è dotato di un parasole frontale ad estensione regolabile, di lunghezza massima 130cm.

- Dimensioni: 350 – 400 – 450 cm
- Peso: 8,3 – 8,7 - 9,1 Kg
- Profondità: 240 cm

OPTIONALS:

• Pareti laterali.

TECHNICAL FEATURES:

*Sun shelter ideal for travelling camping
Practical integrated and adjustable front sunshade, max length 130 cm.*

- Size: 350 – 400 – 450 cm
- Weight: 8,3 – 8,7 - 9,1 Kg
- Depth: 240 cm

OPTIONALS:

• Sidewalls.



TAGLIE DISPONIBILI

350

400

450

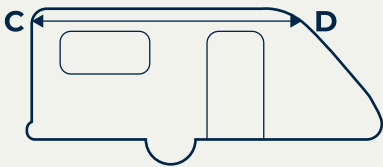

Per determinare la taglia del parasole, rilevare la misura C-D come illustrato nel disegno e confrontarla con i dati riportati nella tabella sopra.



spesso acquistato in abbinamento a
Tappeto per Verande (pag 40)
e **Sedia Velvet** (pag 65)

*often purchased in conjunction with
Tappeto per Verande (pag 40)
ed Velvet Chair (pag 65)*



Parasole per verande

CARATTERISTICHE TECNICHE

Pratico telo supplementare universale per tutte le verande Con.ver (escluso modello "Selva" e "Osaka") che permette di creare una maggiore zona d'ombra.
 • Profondità cm 200

TECHNICAL FEATURES:

Practical universal additional sunshade tent (not available on mod. "Selva" and "Osaka") gives the possibility to create a wider shadow area next to your caravan awning.
 • Depth cm 200



COATED
POLYESTER



26mm
ALUMINIUM
STRUCTURE

LINEA PROMO LINEA CLASSIC

LINEA PROMO	LINEA CLASSIC
	taglia 1
taglia 2	taglia 2
taglia 3	taglia 3
taglia 4	taglia 4
taglia 5	taglia 5
taglia 6	taglia 6
taglia 7	taglia 7
taglia 8	taglia 8
taglia 9	taglia 9
taglia 10	taglia 10
taglia 11	taglia 11
taglia 12	taglia 12
taglia 13	taglia 13
taglia 14	taglia 14
taglia 15	taglia 15



taglia 1-15

MODULO D'ORDINE ORDER FORM

MODELLO CARAVAN / CARAVAN MODEL

ANNO DI COSTRUZIONE / PRODUCTION YEAR

*MODELLO VERANDA / AWNING MODEL

*TAGLIA VERANDA / AWNING SIZEQUANTITÀ / QUANTITY

*Committente / Customer

.....

*Data / Date*Firma / Signature

*** Dati obbligatori - Obligatory data:**

A-B (sviluppo perimetrale / A-B measure) cm.

C-D (architrave h190 / C-D measure h190) cm.

E-F (architrave h100 / E-F measure h100) cm.

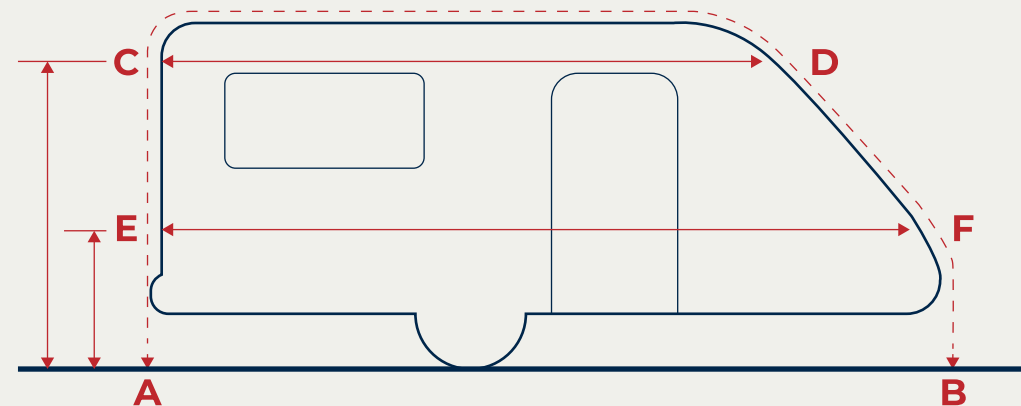

PRODUZIONI SPECIALI SPECIAL PRODUCTION

È possibile produrre verande speciali solo ed esclusivamente nei periodi di bassa stagione (Ottobre-Gennaio).

Per le verande speciali il cliente deve obbligatoriamente compilare il modulo d'ordine, rendendosi responsabile delle misure indicate. CON.VER valuterà l'eventuale possibilità di realizzazione e comunicherà tempestivamente il costo di produzione.

A garanzia di una corretta determinazione della taglia per la vostra veranda, CON.VER consiglia di compilare il modulo d'ordine in tutte le sue parti.

CON.VER si riserva il diritto di valutare i dati inseriti ed apportare modifiche ai fini di stabilire la corretta taglia della veranda.

I dati riportati devono essere chiari e precisi al fine di una corretta interpretazione. CON.VER declina ogni responsabilità per i dati dichiarati che non sono conformi ai normali parametri di produzione.

It is possible to manufacture special verandas only and exclusively in the low season periods (Octobers-January).

For special awnings the customer shall compulsorily fill in the order form, being responsible for the measurements indicated. CON.VER will assess any possibilities of designing and will duly inform the customer about the manufacturing cost.

To guarantee right size of your awning CON.VER suggest to fill the following order form in each gap.

CON.VER reserves for itself the right to evaluate the integrated data and to bring modifications to establish the awning's right size.

The declared data have to be clear and careful for an exact interpretation.

CON.VER refuse all responsibility for the declared data which are not conformable to the normal production parameters.

Paleria supplementare

PALI IN ALLUMINIO ALUMINIUM POLES

CARATTERISTICHE TECNICHE

- Palo in alluminio elettrosaldato lunghezza utile 2,5 mt
- Sistema di chiusura rapido
- Diametro 26 mm, spessore 1,5 mm
- Diametro 22 mm, spessore 1,3 mm

TECHNICAL FEATURES:

- Electrowelded aluminium pole length 2,5 mt
- Quick fastener system
- Diameter 26 mm, thicknes 1,5 mm
- Diameter 22 mm, thicknes 1,3 mm



ALUMINIUM
STRUCTURE

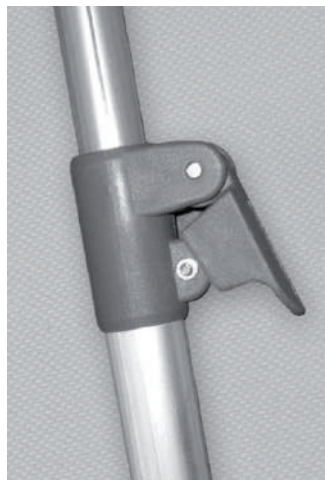

Sistema di chiusura rapido

MODELLO MODEL

- A
- B
- C
- D
- E
- F

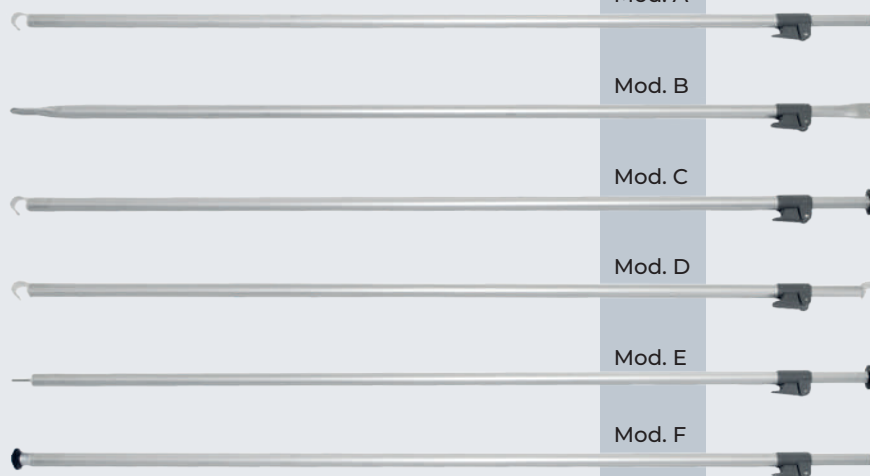

PALI IN ACCIAIO STEEL POLES

CARATTERISTICHE TECNICHE

- Palo in acciaio zincato lunghezza utile 2,5 mt
- Diametro 22 mm, spessore 1 mm
- Diametro 19 mm, spessore 1 mm

TECHNICAL FEATURES:

- Steel galvanized pole length 2,5 mt
- Diameter 22 mm, thicknes 1 mm
- Diameter 19 mm, thicknes 1 mm



STEEL
STRUCTURE



Sistema di chiusura rapido

MODELLO MODEL

- Lamina
- A
- B
- C
- D
- E



Stuoia in PVC



CARATTERISTICHE TECNICHE

Stuoia per veranda in PVC 450g/mq, ideale per l'isolamento al suolo dell'ambiente veranda.

Stabile al suolo, grazie agli occhielli di ancoraggio perimetrali.

Facilmente lavabile, si asciuga velocemente impedendo la formazione di muffa. Morbida, leggera e poco ingombrante, si ripiega e si ripone facilmente grazie alla borsa in dotazione.

TECHNICAL FEATURES:

PVC mat, 450g/mq, ideal for the insulation from the ground.

Stable to the ground, thanks to the perimetral anchoring eyelets.

Very easy to clean, it dries very quickly preventing mould from growing. Soft, lightweight and versatile, it is easy to fold and stock in its carry bag.

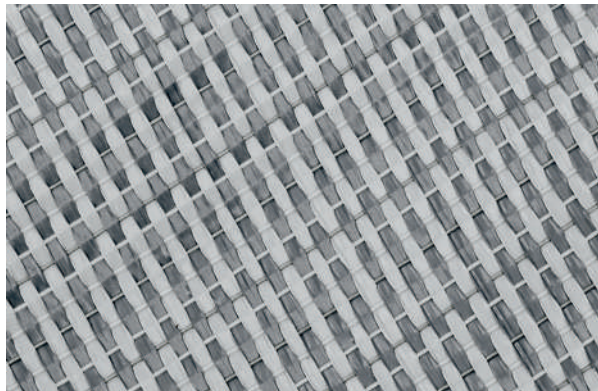

MODELLO

STUOIA 350

DIMENSIONE

cm 350 x 250

STUOIA 400

cm 400 x 250

STUOIA 450

cm 450 x 250

STUOIA 500

cm 500 x 250

STUOIA 550

cm 550 x 250

STUOIA 600

cm 600 x 250



Tappeto per verande

CARATTERISTICHE TECNICHE

Tappeto da campeggio ideale per separare l'ambiente veranda dal suolo. In speciale tessuto in polipropilene a trama fitta impedisce il passaggio di insetti e impurità dal suolo, senza però danneggiare l'eventuale manto erboso con cui è a contatto. Stabile al suolo grazie ai 4 punti di ancoraggio angolari. Leggero, versatile e traspirante asciuga velocemente in caso di umidità impedendo la formazione di muffa.

Velocissimo da pulire con un semplice getto d'acqua. Con stampa double face può essere posato su entrambi i lati. La resistenza ai raggi UV mantiene inalterati nel tempo i colori e le caratteristiche tecniche. Pratico e poco ingombrante si ripiega facilmente. Custodia per il trasporto inclusa.

TECHNICAL FEATURES:

Awning carpet ideal for the insulation from the ground. Its closely-woven polypropylene fabric prevents insects and impurities from passing through, without damaging the grass. Stable, thanks to its four pegging points. Light, versatile and breathable it dries very quickly preventing mould from growing.

Very easy to clean, it only needs a water jet. Reversible design allows a double use according to user's taste. Its UV resistance properties keep colours and efficiency unchanged. Handy, space-saving and easy folding. Carry bag included.



PHthalates FREE
LEAD FREE

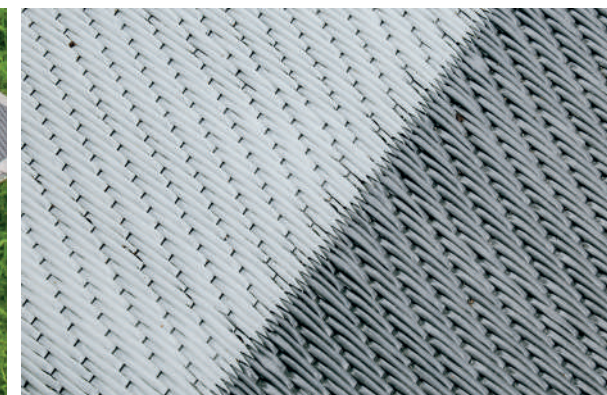

MODELLO

TAPPETO 350
TAPPETO 400
TAPPETO 450
TAPPETO 500
TAPPETO 550
TAPPETO 600

DIMENSIONE

cm 350 x 250
cm 400 x 250
cm 450 x 250
cm 500 x 250
cm 550 x 250
cm 600 x 250

MADE IN ITALY

CON.VER 

COMPACT 2XL



TENDE

MADE IN ITALY

TENDE

COMPACT 2XL



COMPACT 2XL



CARATTERISTICHE TECNICHE

La tenda COMPACT 2XL, è la tenda ideale per gli amanti della vacanza open-air. Estremamente veloce e semplice nel montaggio, COMPACT 2XL è dotata di un'innovativa struttura che utilizza un resistente arco pneumatico gonfiabile che sostituisce la tradizionale paleria. Le sue dimensioni contenute, il peso ridotto e anche l'ampio spazio interno, fanno di COMPACT 2XL la giusta soluzione per chi si accosta per la prima volta all'esperienza del campeggio.

CARATTERISTICHE TECNICHE

- Tessuto IGNIFUGO
- Pavimento in PE 130g integrato
- Struttura integrata costituita da un tubolare gonfiabile ad alta pressione
- Ampia porta a "D" anteriore in poliestere con cerniera
- Finestre frontali in cristal e oscurante
- Ancoraggi antivento

CARATTERISTICHE TECNICHE CAMERA INTERNA

- Telo in poliestere traspirante
- Camera unica con lucernaio al tetto in zanzariera e oscurante esterno
- Tasche portaoggetti nella camera
- Pavimento in PE integrato

TECHNICAL FEATURES:

COMPACT 2XL is the ideal accommodation for tent-lovers, ready to live an open-air vacation. This tent is extremely fast and simple to assemble, thanks to its innovative "all-in-one" structure with a high pressure inflatable tubular instead of traditional poles. Its limited dimensions and weight and its large inner space, make COMPACT 2XL the right solution for those who try camping experience for the first time.

TECHNICAL FEATURES:

- FIRE RESISTANT fabric
- 130g PE sewn-in groundsheet
- "All-in-one" inflatable tubular structure
- Wide "D"-shaped front door with a single zip
- Front transparent PVC windows with blind
- Guy ropes

TECHNICAL FEATURES INNER ROOM:

- Breathable polyester inner tent
- Single room with mosquito netting
- Access doors to rooms in polyester and mosquito netting skylight with outer blind which can be rolled up and opened entirely
- Storage compartments into the bedroom
- PE sewn-in groundsheet



Peso/Weight

7 kg



Dim. prodotto/product

cm 160x300x120h

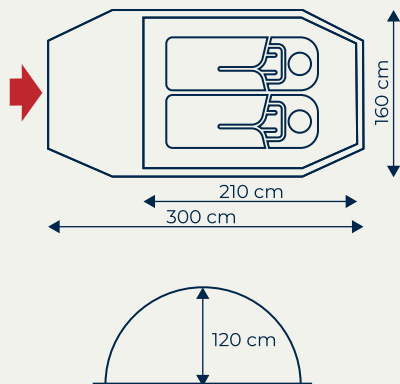
COATED
POLYESTERHEAT-SEALED
SEAMS2000
mm
WATER
COLUMNINFLATABLE
STRUCTUREINFLATOR
INCLUDEDx
2
PEOPLEBAG
INCLUDEDFIRE
RESISTANT

TENDE

TIERRA 5



TIERRA 5



L'innovativa tecnologia del tubolare gonfiabile sta alla base della filosofia costruttiva della tenda TIERRA 5. Praticità, capienza e velocità di montaggio si fondono per dar vita ad una tenda di alto livello. Dotata di pavimento integrato, garantisce il massimo isolamento. TIERRA 5 è la tenda ideale per il campeggio estivo.

CARATTERISTICHE TECNICHE

- Tessuto IGNIFUGO
- Pavimento in PE 130g integrato
- Tubolari gonfiabili ad alta pressione
- Porta laterale sinistra in zanzariera e oscurante esterno
- Finestra frontale in cristal e oscurante interno
- Ampia finestra laterale destra in cristal e oscurante interno
- Ancoraggi antivento
- Cerniera passacavo
- Gonfiatore incluso

CARATTERISTICHE TECNICHE CAMERA INTERNA

- Camera unica amovibile dotata di divisorio incernierato avvolgibile
- Due porte di ingresso alle camere in poliestere e zanzariera
- Capienti tasche portaoggetti fra le due porte di accesso alle camere
- Pavimento in PE integrato

The innovative technology of inflatable tubular lays behind the construction philosophy of TIERRA 5. Maximum functionality, capacity and user-friendliness are a good mix which gives this tent a high level profile. Its sewn-in groundsheet grants the best isolation. TIERRA 5 is the perfect tent for summer camps.

TECHNICAL FEATURES:

- FIRE RESISTANT fabric
- 130g PE sewn-in groundsheet
- Inflatable high-pressure tubular
- Left side door in mosquito netting and outer blind
- Transparent PVC front window with inner blind
- Wide transparent PVC right side window with inner blind
- Guy ropes
- Cable entry
- Inflator included

TECHNICAL FEATURES INNER ROOM:

- Removable single cabin room with divider
- Access doors to rooms in polyester and mosquito netting
- Large storage compartments between the two rooms
- PE sewn-in groundsheet

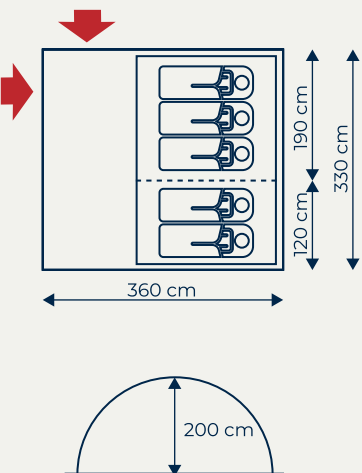

LENDE



Peso/Weight
18,5 kg



Dim. prodotto/product
cm 360x330x200h



Stand



Stand



CARATTERISTICHE TECNICHE

- Gazebo ad apertura automatica con struttura rinforzata in acciaio verniciato e gambe regolabili.
- Tetto in poliestere con cuciture nastrate.
- Borsa per il trasporto e picchetti inclusi.
- Gambe in acciaio verniciato 30x30 mm
- Elemento pantografato 26x13 mm

OPTIONAL

- Pareti

TECHNICAL FEATURES:

- Automatic set up gazebo with reinforced powder coated steel frame and adjustable legs.
- Polyester roof with seam taped.
- Carry bag and pegs included.
- Powder coated steel legs 30x30mm
- Cross bar section 26x13mm

OPTIONAL

- Sidewalls



MODELLO	DIMENSIONE	PESO
STAND	300 x 300 cm	15 kg
LATERALE 3 mt chiuso	300 cm	2 kg
TETTO DI RICAMBIO 3x3 bianco	300 x 300 cm	4 kg

DISPONIBILE ANCHE
CON STAMPA PERSONALIZZATA





CON.VER e YOUTUBE

Guarda nei video
la versatilità
dei nostri prodotti!

*Check the videos on our
youtube channel.
And see the
versatility our items.*

YouTube

Cerca

Home
Tendenze
Iscrizioni

RACCOLTA
Cronologia
Guarda più tardi
Video piaciuti

ISCRIZIONI
Popolari su YouT...
Musica
Sport
Videogiochi

ALTRO DA YOUTUBE
YouTube Premium
Film su YouTube
Videogiochi
Dal vivo
Impostazioni
Cronologia segna...
Guida
Invia feedback

Informazioni Stampa
Copyright Contattaci Creator
Pubblicità Sviluppatori

Termini Privacy
Norme e sicurezza
Prova le nuove funzioni

© 2018 YouTube, LLC

ConVer Tende ISCRIVITI

HOME PAGE VIDEO PLAYLIST CANALI DISCUSSIONE INFORMAZIONI

Veranda Caravan SAHARA - Con.Ver Tende 479 visualizzazioni • 5 mesi fa

In questo video vi mostriamo come montare una veranda caravan Con.Ver

Di seguito le CARATTERISTICHE TECNICHE della veranda per roulotte Sahara:

Tetto in tessuto poliestere biapalmato PVC da 530 gr/mq
ULTERIORI INFORMAZIONI

Video caricati RIPRODUCI TUTTI

Cucinetto gonfiabile DOMUS - Con.Ver Tende 11 visualizzazioni • 3 settimane fa	Tenda gonfiabile TIERRA - Con.Ver Tende 21 visualizzazioni • 3 settimane fa	Veranda per roulotte SAFARI - Con.Ver Tende 4 visualizzazioni • 3 settimane fa	Tenda cucina RAPID - ConVer Tende 8 visualizzazioni • 3 settimane fa	Veranda per camper LIVING ROOM DELUXE - Con.Ver 687 visualizzazioni • 5 mesi fa

Verande per roulotte RIPRODUCI TUTTI



COME SCEGLIERE LA TENDA CUCINA GIUSTA

HOW TO CHOOSE THE RIGHT KITCHEN TENT

Stai cercando una tenda cucina a montaggio rapido?
Are you looking for a quick-assembly kitchen tent?



Multicab pag 50

Multicab è la risposta alle tue esigenze. La leggerezza dei materiali e la semplicità della struttura ne agevolano l'installazione. È ideale per brevi periodi di utilizzo.

Multicab is the answer to your needs. The lightness of the materials and the simplicity of the frame make it easy to install. It is ideal for short periods use.

Vuoi il comfort di un design tradizionale senza rinunciare alla convenienza?
Do you want the comfort of a traditional design without sacrificing convenience?



Dakota pag 50

Dakota è la tenda cucina dal design classico. I materiali utilizzati e la semplicità delle rifiniture contribuiscono a garantire un ottimo rapporto qualità/prezzo. È indicato per l'utilizzo in una vacanza di breve o medio periodo.

Dakota is the kitchen tent with a classic design. The materials used and the simplicity of the finishes help to ensure an excellent quality/price ratio. It is suitable to be used on a short or medium-term holiday.

Sei alla ricerca di un prodotto che soddisfi le tue esigenze di vacanza stanziale?
Are you looking for an item that meets your requirement for a residence vacation?



Hobby pag 51

Indirizza la tua scelta su Hobby, che, grazie all'impiego di materiali ad elevata resistenza agli agenti atmosferici, rappresenta la tua tenda cucina ideale.

Address your choice to Hobby, which, thanks to the employment of high weather resistance materials, represents your ideal kitchen tent.

Multicab

Dakota



LENDE CUCINA

Multicab rappresenta la scelta migliore per creare un riparo ad uso spogliatoio, doccia o bagno. Ideale per un utilizzo in aree quali parchi, spiagge, in campeggio ecc. La porta agevola l'accesso, mentre la paleria è composta da segmenti in fibra di vetro. Ancoraggi antivento incluso

Multicab is a portable tent. It is the right choice to make a private shelter for dressing room, shower or toilet. It can be used in public places as park, beach, campsite etc. The door, equipped with zip, is easy for entry or exit. It's supported by flexible fiberglass frame. Anchor ropes included

 **Peso/Weight**
2,8 kg

 **Dim. prodotto/product**
cm 150x150x210h



 POLYESTER  FIBERGLASS STRUCTURE  WATER COLUMN 1000 mm

Versatile cucinotto con porta avvolgibile sulla parete anteriore, finestre con profili arrotondati sui tre lati, dotate di zanzariera e coprifinestre incernierati. 3 finestre a 2 strati, cristal quadrettato e zanzariera e copertura finestre incernierata

Kitchen tent with frontal rounded door, mesh windows with squared cristal zipped cover. 3 windows with 2 layers, mesh and squared cristal and zipped window cover.

 **Peso/Weight**
13 kg 15 kg 16,9 kg

 **Dim. prodotto/product**
cm 150x150x190/215h cm 200x150x190/215h cm 200x200x190/215h

 PVC ROOF  COATED POLYESTER  STEEL STRUCTURE

Hobby



Tenda cucina con tre finestre in zanzariera e copri finestra incernierati, facciata con porta arrotolabile e finestra in cristallo fumé.

OPTIONAL

· Tendina per finestra frontale

Kitchen tent with 3 mesh windows with zipper cover, facade with rollable door and smoked cristal window.

OPTIONALS:

· Frontal window curtains.



Peso/Weight

21 kg

22,3 kg



Dim. prodotto/product

cm 200x200x190/215h

cm 250x200x190/215h

TENDE CUCINA



CON.VER su FACEBOOK

<https://it-it.facebook.com/convertende/>

Seguici
e scopri tutte
le novità!

*Follow us
and discover
all the news!*



Usiamo i cookie per personalizzare i contenuti, rivolgere le inserzioni al pubblico giusto e misurarle e per fornire un'esperienza più sicura. Cliccando o navigando sul sito, accconsenti alla raccolta da parte nostra di informazioni su Facebook e fuori da Facebook tramite i cookie. Scopri di più anche sulle opzioni di scelta disponibili: [Normativa sui cookie.](#)

facebook

E-mail o telefono Password [Accedi](#)
Non ricordi più come accedere all'account?

CON.VER

Con.ver Tende
@convertende

Home
Foto
Video
Post
Informazioni
Community
Informazioni e inserzioni
[Crea una Pagina](#)

Mi piace [Condividi](#) [...](#) [Contattaci](#) [Invia un messaggio](#)

Foto

Cerca post in questa Pagina

Con.ver Tende
Azienda di commercio al dettaglio a Lodi
[Chiusa ora](#)

Informazioni CON.VER TENDE

CON.VER È ... ATTENZIONE AI DETTAGLI

Attenzione ai dettagli, è ciò che ci caratterizza e contraddistingue.
Nel nostro laboratorio vengono...
[Altro...](#)

Rosty



Rosty è il forno a gas portatile che va incontro alle esigenze di chi ama il campeggio o è un appassionato di nautica.

Il forno consente una cottura su più livelli, mentre la parte superiore si compone di due fuochi con tripla schermatura dal vento, per prevenire lo spegnimento della fiamma.

La struttura del forno è in acciaio con due pratiche maniglie integrate nella struttura.

Il forno è stato concepito per funzionare ad alte temperature per lungo tempo, il termometro integrato consente di tenere sempre sotto controllo la temperatura di cottura.

La pratica borsa in dotazione consente di trasportare agevolmente il forno e di preservarlo dalla polvere quando non utilizzato.

CARATTERISTICHE TECNICHE

- Accensione piezoelettrica.
- Bruciatore interno del forno da 1,5 Kw con dispositivo di sicurezza in caso di fiamma mancante.
- Forno non ventilato.

Rosty is the portable gas oven that meets the demands of those who are fond of camping and outdoor activities and for the enthusiasts of boating.

The oven allows cooking on multiple levels, while the two burners stove has a triple wind shielding to prevent flame extinguishing.

The oven structure is made of stainless steel, having two practical integrated handles.

The oven is designed to operate at high temperatures for a long time; the integrated thermometer ensures that cooking food is held at safe temperatures.

The supplied carry bag is practical for easily carrying the oven and save it from dust when not used.

TECHNICAL FEATURES:

- Piezo-electric ignition.
- 1,5 Kw inner burner with flame failure device.
- Unventilated oven.



Peso/Weight

15 kg



Dim. prodotto/product

cm 63x36.5x50



King Comfort

Materassino auto-gonfiante, con spessore di 10 centimetri. Pratico per l'utilizzo a terra o su un lettino o all'interno di un veicolo ricreazionale.

CARATTERISTICHE TECNICHE

- Struttura interna: Imbottitura con struttura a nido d'ape in poliuretano ad alta densità con spessore di 10 cm
- Tessuto: Tessuto esterno superiore in poliestere accoppiato con uno strato in TPU. Tessuto esterno inferiore, a contatto con il terreno, in Oxford impermeabile accoppiato con uno strato di TPU

Self-inflating mat with 10 cm thickness. Easy use outdoor, directly on the ground, on a camping bed, or in a recreational vehicle. Carry bag included

TECHNICAL FEATURES:

- High density honeycomb PU foam 10 cm thickness
- Top & side fabric: soft touch honeycomb stretch polyester with TPU laminated. Base: durable waterproof Oxford with laminated TPU

**AUTOGONFIANTE
10 CM DI SPESSORE**



Peso/Weight

3,5 kg

Peso/Weight

6 kg



Dim. prodotto/product

cm 195x80x10 cm

Dim. prodotto/product

cm 195x140x10 cm

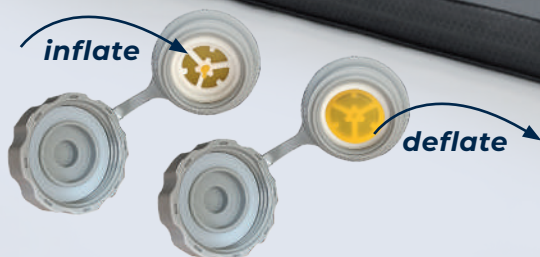
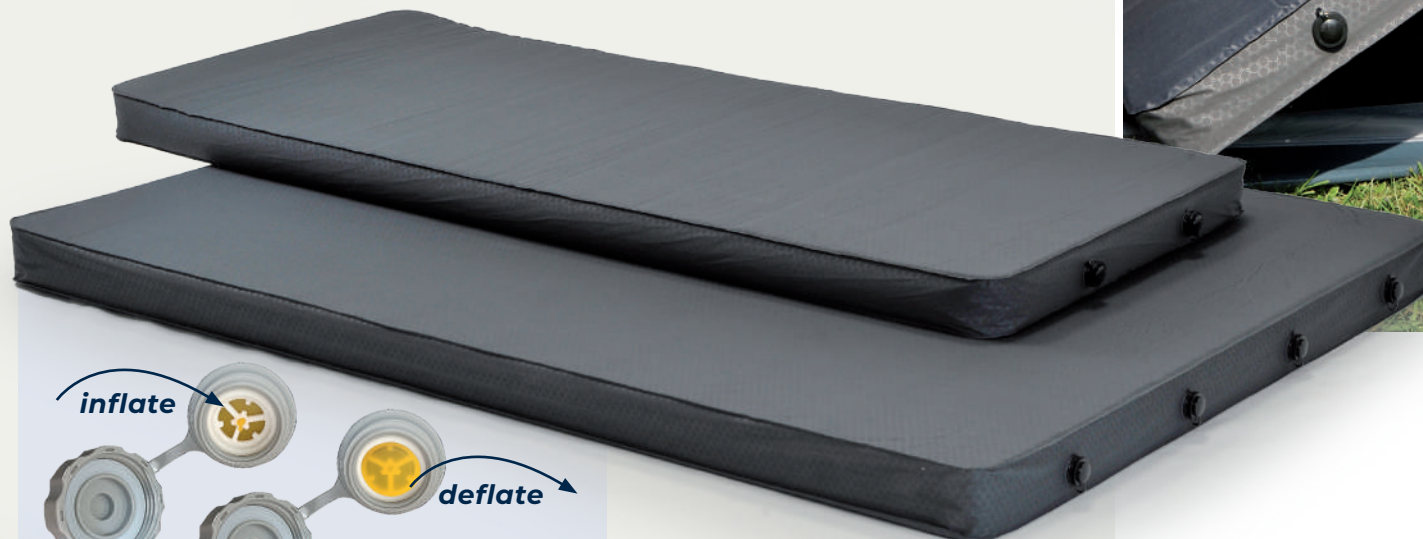

Trend



 Peso/Weight
2,4 kg

 Dim. prodotto/product
cm (200+25)x80 cm

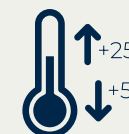

TAVOLI e SEDIE

Cargo Beach

Trolley multifunzione con quattro ruote anti incaglio e pratica maniglia per il traino.
La sponda posteriore dotata di due porta bicchieri si può abbassare fungendo da ripiano ed ampliando il volume di carico. Pratiche tasche laterali per il trasporto di oggetti di lunghe dimensioni.

Borsa per il trasporto inclusa.

*Multifunction trolley with four anti-beaching wheels and a practical handle for an easy control.
Pantograph folding system for a compact storage. The backside with two cup holder, can be lowered increasing the load volume. Pratical side pockects for long objects.
Carry bag included.*

-  **Peso/Weight**
11,6 Kg
-  **Dim. prodotto/product**
cm 94x49x58 cm
-  **Portata/Load capacity**
50Kg



NEW
product

Cargo Fresh



Trolley multifunzione con quattro ruote anti-incaglio e pratica maniglia per il traino.
Il vano posteriore con pratica borsa termica estraibile e struttura ripiegabile con borsa inclusa.

*Multifunction trolley with four anti-beaching wheels and a practical handle for an easy control.
Practical handle for an easy control.
Rear compartment with practical extacable cool bag.
Pantograph folding system for a compact storage. Carri bag included.*

-  **Peso/Weight**
12,50 Kg
-  **Dim. prodotto/product**
113x49x58/100 cm
-  **Portata/Load capacity**
50 Kg



-  **PAINTED STEEL STRUCTURE**
-  **POLYESTER 500D**
-  **360° ANTI-TANGLING WHEELS**
-  **BAG INCLUDED**

PROBLEMI NELLA SCELTA DELLA SEDIA GIUSTA PROBLEMS IN CHOOSING THE RIGHT CHAIR



SEDIE

CONFORTEVOLE

Per chi è in cerca di una poltrona reclinabile in più posizioni, dall'alto schienale e dall'elevato comfort, la scelta giusta è rappresentata dai modelli Komfy, Zodiac, Recliner e Silla.

For those looking for a several position recliners, with a high backrest and high comfort, the right choice is represented by the Komfy, Zodiac, Recliner and Silla models.

Komfy pag. 58-59



Zodiac pag. 60



Recliner pag. 60



Silla pag. 61



TRASPORTO FACILE

Invece chi ha la necessità di un prodotto facile da trasportare e che non occupi molto spazio, adatto in particolare a chi ama le vacanze in van, può scegliere tra le poltroncine con chiusura a pantografo Mercury, Club e Swing.

On the other hand, those who need a product that is easy to transport and does not take up much space, particularly suitable for those who love van holidays, can choose among the Mercury, Club and Swing armchairs with pantograph closure.

Mercury pag. 63



Club pag. 62



Swing pag. 64



POLIFUNZIONALE

Chi fosse alla ricerca di una sedia polifunzionale adatta sia per sedersi attorno ad un tavolo per pranzo o per una breve sosta, la potrà selezionare nell'ampia e varia gamma di sedie regista.

Those looking for a multifunctional chair suitable for sitting around a table for lunch or for a short stop, can select it from the wide and varied range of director chairs.

pag. 66-67-68



I MATERIALI

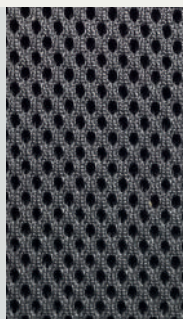

3D MESH

Le sedie sdraio Recliner e Komfy con il poggia piedi Apex, la sedia regista Velvet, la poltroncina Club ed il lettino Galaxy, hanno come caratteristica principale il tessuto 100% poliestere 3D mesh. La trama di questo tessuto garantisce un'elevata circolazione dell'aria rendendolo particolarmente traspirante, questo consente alla linea di prodotti che adottano questo materiale di asciugarsi rapidamente in caso di pioggia. Un'altra caratteristica di questo materiale è la morbidezza al tatto che incrementa il comfort del prodotto durante un utilizzo prolungato.

The model Recliner and the Komfy chair with Apex footrest, the Velvet director chair, the Club armchair and the Galaxy lounger, have as their main feature the 100% polyester 3D mesh fabric. The weave of this fabric guarantees high air circulation making it particularly breathable, this allows the line of products that adopt this material to dry quickly in case of rain. Another characteristic of this material is its softness to the touch, which increases the comfort of the product during a prolonged use.

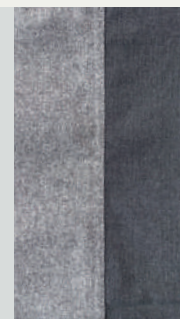

DDY

La linea di prodotti che comprende le poltroncine Mercury e Swing, la sedia regista Action e la sdraio Silla col poggia piedi Jolly è caratterizzata dall'impiego per sedute e schienali del tessuto DDY. Il tessuto DDY si distingue dagli altri (impiegati) perché il filato utilizzato per la sua realizzazione "viene tinto in massa" anziché subire un processo di tintura in un secondo momento. Questo tipo di tessuto oltre ad essere gradevole al tatto ed esteticamente ha l'importante caratteristica di avere un'elevata resistenza ai raggi UV.

The product line that includes the Mercury and Swing armchairs, the Action director chair and the Silla deck chair with the Jolly footrest is characterized by the use of DDY fabric for seats and backrests. The DDY fabric differs from other used fabrics because the yarn used to make it is dope-dyed rather than undergoing a dyeing process at a later moment. This type of fabric, in addition to being pleasant to the touch and aesthetically, has the important characteristic of having a high resistance to UV rays.



UN TAVOLO PER OGNI SITUAZIONE A TABLE FOR EVERY SITUATION

Nell'ambito delle vacanze outdoor la scelta del tavolo giusto può essere influenzata da diversi fattori. Ad esempio, la funzione che il tavolo andrà a ricoprire, la modalità di trasporto ed il tipo di montaggio

In the context of outdoor holidays, the choice of the right table can be influenced by various factors. For example, the function that the table will cover, the transportation mode and the assembly method.

linea SALVASPAZIO

Per andare incontro all'esigenza di chi non ha molto spazio di carico proponiamo i tavoli Modus e Wood nelle misure 120cm – 140cm – 160cm. La struttura pieghevole ed il ripiano arrotolabile garantiscono una chiusura compatta, rappresentando una valida soluzione salvaspazio.

To meet the requirement of those who do not have much cargo space, we offer the Modus and Wood tables in the sizes 120cm – 140cm – 160cm. The foldable structure and the roll-up top, guarantee a compact closure, representing a valid space-saving solution.

Modus pag. 72



Wood pag. 73



linea FUNZIONALE

Chi desidera un tavolo funzionale, di facile installazione, senza però rinunciare all'estetica può optare per i tavoli ultraleggeri Superlite e Moon. Caratterizzati da finiture effetto legno e pietra.

Those who want a functional table, easy to install, without forgoing aesthetics, can opt for the ultra-light Superlite and Moon tables. Characterized by wood and stone effect finishes.

Superlite pag. 74



Moon pag. 75



? PERCHÉ ULTRALEGGERO WHY ULTRALIGHT

I tavoli Superlite e Moon sono i rappresentanti della nostra linea ultraleggera. I piani di questi tavoli sono delle tavole leggere composite. Ideali per la costruzione di mobili da esterno, i pannelli compositi hanno caratteristiche intrinseche di impermeabilità, resistenza e leggerezza. La tavola è composta da una struttura portante a nido d'ape in polipropilene (SUPERLITE) o in alluminio (MOON) che viene poi ricoperta da strati di fibra di vetro con resina. Dopo una cottura in forni specifici per circa due ore, viene aggiunta una superficie di carta melaminica che consente differenti finiture.

The Superlite and Moon tables are the representatives of our ultra-light line. The tops of these tables are lightweight composite boards. Ideal for the construction of outdoor furniture, composite boards have intrinsic characteristics of waterproofing, resistance and lightness. The board consists of a honeycomb supporting structure made of polypropylene (SUPERLITE) or aluminium (MOON) which is then covered with layers of fiberglass with resin. After firing in specific kilns for about two hours, a melamine paper surface is added allowing different finishes.

Superlite pag. 74

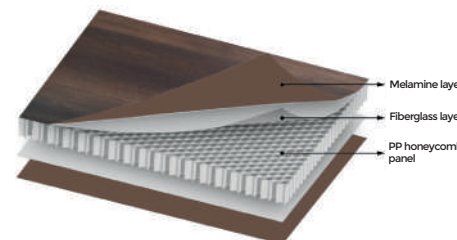

Moon pag. 75

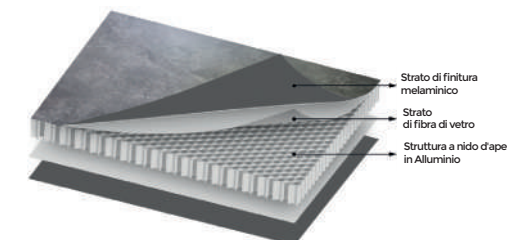

Komfy blu

Apex blu





TAVOLI e SEDIE

Poltrona imbottita con schienale sagomato.
Reclinabile in 7 posizioni.

*Foam padded armchair with shaped backrest.
Adjustable to 7 positions.*

 *Peso/Weight*
5,5 Kg

 *Dim. prodotto/product*
cm 48x40x46/119h cm

 *Portata/Load capacity*
120Kg

Poggiatesta pieghevole per sedia a sdraio
Komfy blu.

Footrest suitable for chair Komfy blu.

 *Peso/Weight*
1,3 Kg

 *Dim. prodotto/product*
97x43x44h cm

 *Portata/Load capacity*
20Kg

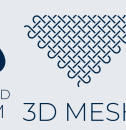
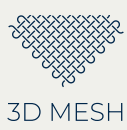

Komfy grigia

Apex grigia



Poltrona imbottita con schienale sagomato. Reclinabile in 7 posizioni.





Foam padded armchair with shaped backrest. Adjustable to 7 positions.





-  **Peso/Weight**
5,5 Kg
-  **Dim. prodotto/product**
cm 48x40x46/119h cm
-  **Portata/Load capacity**
120Kg

Poggiapiedi pieghevole per sedia a sdraio Komfy grigia.

Footrest suitable for chair Komfy grey.

-  **Peso/Weight**
1,3 Kg
-  **Dim. prodotto/product**
97x43x44h cm
-  **Portata/Load capacity**
20Kg

 PAINTED ALUMINIUM STRUCTURE
  3D MESH
  SUPER SOFT SEAT/BACKREST
  EXTERNAL USE

 PAINTED ALUMINIUM STRUCTURE
  3D MESH
  SUPER SOFT SEAT/BACKREST
  EXTERNAL USE

Zodiac



Robusta poltrona reclinabile in sette posizioni. Dotata di cuscino interno.

Seven positions adjustable heavy duty reclining chair. Equipped with inside pillow. Easy to open and fold.

 **Peso/Weight**
5 Kg

 **Dim. prodotto/product**
48x42x46/120h cm

 **Portata/Load capacity**
120Kg



Recliner



Poltrona imbottita pieghevole completamente reclinabile, con poggia piedi integrato.

Padded and fully reclining armchair, with integrated footrest

 **Peso/Weight**
10,3 Kg

 **Dim. prodotto/product**
56x54x51/121 cm

 **Portata/Load capacity**
120Kg

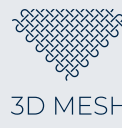

Silla

NEW
product



Poltrona imbottita in tessuto DDY, con schienale reclinabile in 6 posizioni.

Padded, DDY fabric armchair with back rest adjustable to 6 positions

 **Peso/Weight**
5,22 Kg

 **Dim. prodotto/product**
49x45x49/122 cm

 **Portata/Load capacity**
120Kg



Jolly

NEW
product



Poggiapiedi pieghevole per sedia a sdraio Silla.

Padded footrest suitable for chair Silla.

 **Peso/Weight**
1,64 Kg

 **Dim. prodotto/product**
56x47x47,5cm

 **Portata/Load capacity**
30Kg



Club

Sedia pieghevole imbottita con comodo schienale alto, regolabile in 4 posizioni

Padded folding chair with comfortable high backrest, 4 positions adjustable, and artrest.



Peso/Weight
5,3 Kg



Dim. prodotto/product
76x62x110 cm



Portata/Load capacity
120 Kg



PAINTED
ALUMINIUM
STRUCTURE



3D MESH



SUPER SOFT
SEAT/BACKREST



EXTERNAL
USE



BAG
INCLUDED

Mercury

Poltrona pieghevole con braccioli. Pratica e con ingombro minimo.

Folding armchair with armrest. handy and space saving



Peso/Weight

4,8 Kg



Dim. prodotto/product

52x43x48/93cm



Portata/Load capacity

120 Kg



Swing

Poltrona pieghevole salvaspazio con braccioli. Dotata di innovativo giunto metallico che consente alla sedia di oscillare dolcemente, garantendo il confort di una sedia a dondolo.

Space saving folding armchair with armrest. Equipped with an innovative metal joint allow a soft swinging. The confort of a swinging chair is guaranteed.



-  **Peso/Weight**
6,9 Kg
-  **Dim. prodotto/product**
56x44x47/93cm
-  **Portata/Load capacity**
100 Kg

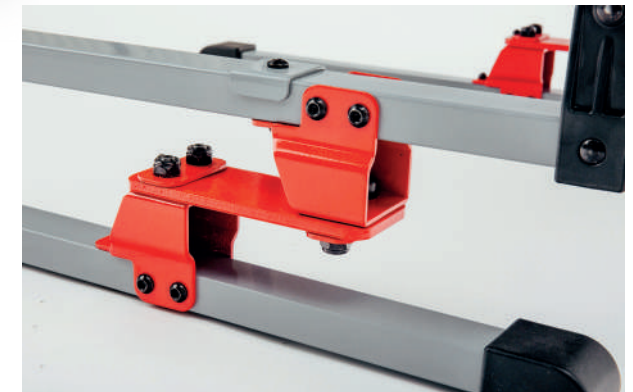

Velvet grigia

Sedia regista deluxe con seduta e schienale imbottiti. Dotata di tavolino con porta bicchiere su un lato e di comode tasche sull'altro lato.

Deluxe director chair with foam padded seat and backrest. Equipped with side table with drink holder and useful pockets on the other side.



Peso/Weight

3,5 Kg



Dim. prodotto/product

50x45x46/83h cm



Portata/Load capacity

100 Kg



ALUMINIUM
STRUCTURE



3D MESH



SUPER SOFT
SEAT/BACKREST





EXTERNAL
USE

Custom



 *Peso/Weight*
2,5 Kg

 *Dim. prodotto/product*
61x50x48/80h cm

 *Portata/Load capacity*
100 Kg

Sedia **personalizzabile**
con un minimo d'ordine
pari a **12 pezzi**

Customizable chair
with a minimum of **12 pcs**



Prima



 *Peso/Weight*
2,5 Kg

 *Dim. prodotto/product*
61x50x48/80 h cm

 *Portata/Load capacity*
100 Kg



Mesh



Action

NEW
product



Peso/Weight 
2,5 Kg

Dim. prodotto/product 
57x47x49/80h cm

Portata/Load capacity 
100 Kg

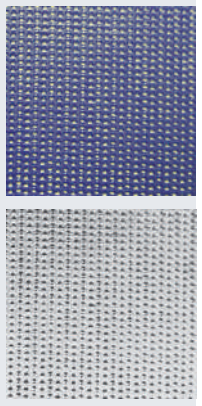



 24mm
ALUMINIUM STRUCTURE

 TEXTILENE
330g/mq

 EXTERNAL USE

Peso/Weight 
3,16 Kg

Dim. prodotto/product 
47x40x47/86 cm

Portata/Load capacity 
120 Kg

 25mm
PAINTED ALUMINIUM STRUCTURE

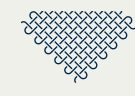
 DDY

 SUPER SOFT SEAT/BACKREST

Academy

Virgo





TAVOLI e SEDIE

-  *Peso/Weight*
2,1 Kg
-  *Dim. prodotto/product*
47x57x97 cm
-  *Portata/Load capacity*
100 Kg



Sgabello pieghevole. Con pratica borsa per il trasporto.

Foldable stool with carry bag for an easy transport

-  *Peso/Weight*
0,9 Kg
-  *Dim. prodotto/product*
40x27x46 cm
-  *Portata/Load capacity*
80 Kg







Galaxy blu

Letino regolabile in 5 posizioni, con seduta imbottita e comodo cuscino.

Folding beach bed adjustable to 5 positions, with padded seat and comfortable pillow.



-  Peso/Weight
7 Kg
-  Dim. prodotto/product
cm 200/144x70x45h
-  Portata/Load capacity
120 Kg

-  PAINTED ALUMINIUM STRUCTURE
-  3D MESH
-  SUPER SOFT SEAT/BACKREST
-  EXTERNAL USE

Astra





TAVOLI e SEDIE

Lettino regolabile in 5 posizioni con cuscino integrato e aletta parasole regolabile

Adjustable bed with integrated pillow and adjustable sun visor

 **Peso/Weight**
7,5 Kg

 **Dim. prodotto/product**
193x66x48 cm

 **Portata/Load capacity**
120 Kg



Morfeo





CARATTERISTICHE TECNICHE

· Brandina pieghevole dalle dimensioni compatte, dotata di una resistente borsa per un pratico trasporto

TECHNICAL FEATURES:

· Camping bed foldable to compact size for easily carrying each in a durable 600D carry bag

 **Peso/Weight**
5,5 Kg

 **Dim. prodotto/product**
190x72x43 h cm

 **Portata/Load capacity**
90 Kg



Premium

NEW
product



Premium 120

KG *Peso/Weight*
8 Kg

Dim. prodotto/product
122x60x74cm

Portata/Load capacity
150 Kg

Premium 150

Peso/Weight
9 Kg

Dim. prodotto/product
152x70x74cm

Portata/Load capacity
150 Kg



Blanca

NEW
product



KG *Peso/Weight*
3 Kg

Dim. prodotto/product
44x44x79cm



Portata/Load capacity
120 Kg



Modus

Tavolo con ripiano a tapparella e telaio pieghevole in alluminio, con gambe in acciaio verniciato e completo di borsa di trasporto con doppia cerniera. Una gamba regolabile.

Aluminium table easily folding as a whole set into a durable carrying bag. Aluminium top with plastic chain connection system. Steel powder coated legs, adjustable foot.

	Modus 120	Modus 140	Modus 160
 Peso/Weight	8 Kg	9 Kg	9,5 Kg
 Dim. prodotto/product	120x80x71h cm	140x80x71h cm	160x80x71h cm
 Portata/Load capacity	30 Kg	30 Kg	30 Kg



Finitura effetto legno
 Wood effect finish



Wood

Tavolo con ripiano arrotolabile in alluminio con effetto legno. Struttura in acciaio con una gamba regolabile. Borsa per il trasporto inclusa.

Table with aluminium roll-up top with wood effect finish. Steel frame with one adjustable leg Carry bag included.

Wood 120	Wood 140	Wood 160	
Peso/Weight	Peso/Weight	Peso/Weight	
4,30 Kg	6,12 Kg	7,20 Kg	
Dim. prodotto/product	Dim. prodotto/product	Dim. prodotto/product	
120x80x71 cm	140x80x71,5 cm	160x80x71,5 cm	
Portata/Load capacity	Portata/Load capacity	Portata/Load capacity	
30 Kg	30 Kg	30 Kg	

? PERCHÉ ANTIGRAFFIO

Tra i pregi del tavolo Wood abbiamo la particolarità di essere antigraffio. Questa caratteristica si ottiene grazie alla finitura del piano che avviene tramite stampaggio a trasferimento termico direttamente su alluminio. In questo processo al metallo vengono applicati un determinato disegno ed una determinata vernice. Tramite un processo di cottura ad alta temperatura si conferisce all'alluminio una finitura termoindurente che garantisce un'elevata durabilità e resistenza ai graffi.

Among the advantages of the Wood table, we have the peculiarity of being scratch-resistant. This feature is achieved thanks to the finishing of the top, achieved by direct thermal transfer molding on aluminum. In this process, a certain design and paint are applied to the metal. Through a high-temperature firing process, the aluminium is given a thermosetting finish that guarantees high durability and scratch resistance.



Superlite

Tavolo pieghevole con piano in fibra di vetro e melamina e con struttura in alluminio con finitura opaca. Caratterizzato da un peso molto ridotto il tavolo è molto facile da aprire ed è inoltre dotato di gambe regolabili.

Ultralight weight folding table with fiberglass and melamine top and finish matt aluminum structure. Easy to open and equipped with adjustable legs.

	Peso/Weight 3,8 Kg
	Dim. prodotto/product 100x68x60/72h cm
	Portata/Load capacity 45 Kg

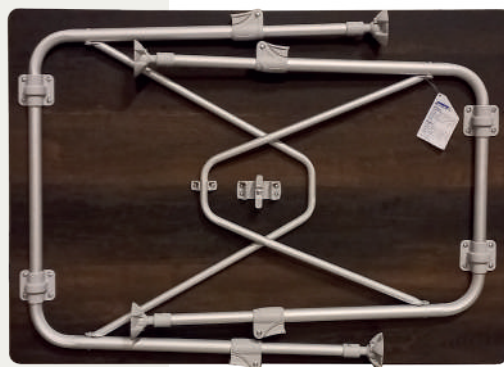

ALUMINIUM
STRUCTURE

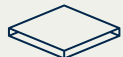

WOOD
EFFECT



HONEYCOMB
STRUCTURE



EXTERNAL
USE

Moon

Tavolo ultraleggero con piano antigraffio effetto marmo con struttura a nido d'ape. Altezza regolabile. Borsa da trasporto inclusa.

Ultralight table with antiscratch marble effect top with honeycomb frame. Adjustable height. Carry bag included

Peso/Weight

6,1 Kg



Dim. prodotto/product

115x70x57/76 cm



Portata/Load capacity

30 Kg



ULTRALIGHT

**ALTEZZA REGOLABILE
 IN 10 POSIZIONI**



Company

Titan

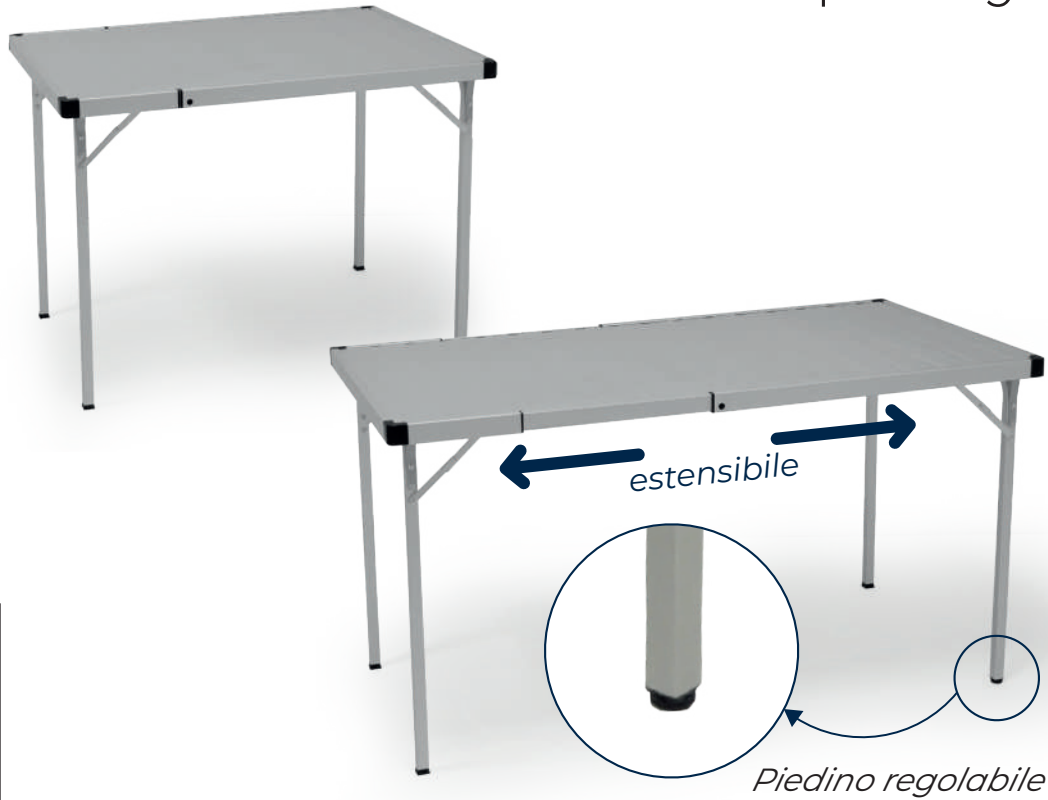

Tavolo multiuso con piano in alluminio e struttura in alluminio con finitura opaca. Il tavolo può essere regolato in larghezza in due posizioni.

Multipurpose table with aluminum top and finish matt aluminum frame. The top can be extended into 2 different positions.



Peso/Weight

7,5 Kg



Dim. prodotto/product

94/130x70x70h cm



Portata/Load capacity

30 Kg



ALUMINIUM
STRUCTURE



ALUMINIUM
TOP



EXTERNAL
USE



BAG
INCLUDED



ALUMINIUM
STRUCTURE



MDF
TOP



BAG
INCLUDED

Tavolo in alluminio con piano in MDF. Facile da aprire e da richiudere per un agevole trasporto. Gambe regolabili.

Aluminum table with MDF top. Easy to open and to refold to a compact size for easy carrying. Adjustable legs.



Peso/Weight

6,5 Kg



Dim. prodotto/product

115x70x75/55 h cm



Portata/Load capacity

30 Kg

Energy



Tavolo in alluminio con ripiano MDF. Le gambe si ripiegano scomparendo sotto il piano con effetto salvaspazio.
 Borsa per il trasporto inclusa.

*Aluminium table with MDF top. The legs fold up disappearing under the top, with space-saving effect.
 Carry bag included.*

Peso/Weight

6,34 Kg



Dim. prodotto/product

120x70x74 cm



Portata/Load capacity

30 Kg



ALUMINIUM
STRUCTURE



MDF
TOP



BAG
INCLUDED

Combo

NEW
product

Aliseo



SCRATCH
RESISTANT



Mobile cucina composto da portaforne e mobile con due ripiani portastoviglie. Dotato di due piani di servizio laterali e borsa per trasporto.

Kitchen cupboard made up of stove stand with fire shield and two dish shaver compartment. Equipped with two side shelves and a carry bag.



Peso/Weight
8,34 Kg



Dim. prodotto/product
66x35x79/110 cm



Portata/Load capacity
30 Kg



Armadio multiuso con ripiani, montaggio facile e veloce, non ci sono tubi da collegare. Top in alluminio, paravento incluso, rete posteriore per ventilazione, doppia apertura frontale. Borsa per il trasporto inclusa.

Three-shelf Deluxe Cupboard, quick and easy to assemble, no need to take the tube out. Aluminium top, wind shield included, rear mesh for ventilation, double opening. Each in a durable carry bag.



Peso/Weight
8 Kg



Dim. prodotto/product
87x51x80/110h cm



Portata/Load capacity
30 Kg

Combi Plus



Mobiletto cucina attrezzato, dotato di lavello, porta utensili, cestino e porta spezie.

Camping kitchen with 2 layer MDF top. Kitchen include, plastic wash basin, utensil rack, waste basket



Peso/Weight

12,5 Kg



Dim. prodotto/product

100x50x77h cm



Portata/Load capacity

40 Kg



Consulta il nostro sito!

PER VISIONARE L'INTERA GAMMA PRODOTTI



e trovare
il rivenditore
più vicino

Thermo Cover



CARATTERISTICHE TECNICHE

Copertura integrale isolante dotata di balza perimetrale per cabine guida di veicoli ricreazionali. Disponibile per quasi tutti i modelli attualmente in commercio.

Parabrezza e vano motore possono essere coperti contemporaneamente o separatamente.

La parte frontale dell'elemento superiore può essere aperta secondo necessità.

Il collegamento tra l'elemento superiore e l'elemento inferiore avviene mediante un nastro di velcro.

Offre un ottimo isolamento grazie allo speciale materiale a 3 strati di spessore 8 mm.

TECHNICAL FEATURES:

Integral insulating cover with outside ledge for RV guide compartments.

Available for almost all the market leaders vehicles.

Windscreen and engine space can be covered at the same time or separately.

The front part of the upper side can be opened if necessary.

The connection between the upper and the lower side is possible thanks to a velcro tape.

It gives a perfect insulation thanks to the excellent 3 layer material with its 8 mm thickness.



**THERMAL
ISOLATION**



**OSCURANTE ESTERNO
VETRI TERMOISOLANTE
3 STRATI**

MODELLO

**OSCURANTE
COFANO-MOTORE
PER GLOBALE**

Fiat Ducato 2002 - 2006

Fiat Ducato 2006 - 2014

Fiat Ducato 2015 >

Ford Transit 2014 >

PVC
 +
 POLYURETHANE
 +
 PVC
TRIPLOLAYER

8 mm
 ↑
 TICKNESS

CARAVAN GUARD

CARATTERISTICHE TECNICHE

- Telo di copertura in tessuto traspirante da 160 g/mq, non impermeabile.
- E' ideale per proteggere la caravan dagli agenti atmosferici durante il rimessaggio invernale.
- E' IMPORTANTE RICORDARE CHE L'UTILIZZO DEL COPRICARAVAN È SCONSIGLIATO DURANTE IL PERIODO ESTIVO. L'ECESSIVA TEMPERATURA A CUI È SOTTOPOSTO IL TESSUTO POTREBBE PRECOCEMENTE DETERIORARLO.
- Le due cerniere verticali permettono l'apertura della parete al fine di agevolare il montaggio o favorire l'accesso durante il rimessaggio.
- Cinghie antivento laterali in dotazione.
- Borsa trasporto inclusa.
- Confezione: 1pz

TECHNICAL FEATURES:

- Non-woven fabric 160g/mq, polypropylene caravan cover.
- Not waterproof, breathable.
- IT'S IMPORTANT TO REMEMBER THAT THE USE OF COPRICARAVAN IS NOT RECOMMENDED DURING THE SUMMER. EXCESSIVE TEMPERATURE UNDERGONE BY THE FABRIC MAY DETERIORATE IT PREMATURELY.
- Suitable to protect caravan against the atmospheric elements, during winter garaging.
- Two zippers make the front removable to help the assembly and the entrance during the garaging period.
- Including carry bag.
- Packaging: 1pcs



COPERTURE

caravan/autocaravan



WINTER PROTECTION



	kg	
mod A	10 Kg	3,70 ▶ 4,20 x 2,30 mt
mod B	11 Kg	4,21 ▶ 5,10 x 2,30 mt
mod C	13 Kg	5,11 ▶ 5,60 x 2,30 mt
mod D	15 Kg	5,61 ▶ 6,10 x 2,50 mt
mod E	17 Kg	6,11 ▶ 6,70 x 2,50 mt

CAMPER GUARD



CARATTERISTICHE TECNICHE

- Telo di copertura in tessuto traspirante da 160 g/mq, non impermeabile.
- E' ideale per proteggere il camper dagli agenti atmosferici durante il rimessaggio invernale.
- E' IMPORTANTE RICORDARE CHE L'UTILIZZO DEL COPRICAMPER È SCONSIGLIATO DURANTE IL PERIODO ESTIVO. L'ECESSIVA TEMPERATURA A CUI È SOTTOPOSTO IL TESSUTO POTREBBE PRECOCEMENTE DETERIORARLO.
- Le tre cerniere verticali permettono l'apertura del fianco per facilitare il montaggio e l'ingresso alla cabina e alla cellula.
- Cinghie antivotto laterali e frontali
- Confezione 1 pz

TECHNICAL FEATURES:

- Non-woven fabric 160g/mq, polypropylene caravan cover.
- Not waterproof, breathable.
- Suitable to protect caravan against the atmospheric elements, during winter garaging.
- IT'S IMPORTANT TO REMEMBER THAT THE USE OF COPRICARAVAN IS NOT RECOMMENDED DURING THE SUMMER. EXCESSIVE TEMPERATURE UNDERGONE BY THE FABRIC MAY DETERIORATE IT PREMATURELY.
- Three zippers make the front removable to help the assembly and the entrance during the garaging period.
- Including carry bag.
- Packaging 1 pcs





**WINTER
PROTECTION**



COPERTURE

caravan/autocaravan

	 Kg	
mod M	15 Kg	6,60 ▶ 7,10 x 2,40 mt
mod L	17 Kg	7,11 ▶ 7,60 x 2,40 mt



VERANDE

CARAVAN/AUTOCARAVAN

Living Room FREEDOM DE LUXE



Living Room FREEDOM DE LUXE



CARATTERISTICHE TECNICHE

- Doppio ingresso sul frontale
- Finestra frontale in cristal con oscurante
- Ingresso laterale (entrambi i lati)
- Finestre laterali in zanzariera e oscurante.
- Aletta isolante tra il tetto ed i fianchi.

Adattabile alla maggior parte dei tendalini Fiamma, Omnistore, Thule e Dometic.

TECHNICAL FEATURES:

- Dual door on the front
- Transparent pvc front window with blind
- Side doors (both sides)
- Side window with blind and mosquito net.
- Insulation flap between the roof and the sides.

Adaptable to most Fiamma, Omnistore, Thule and Dometic awnings.

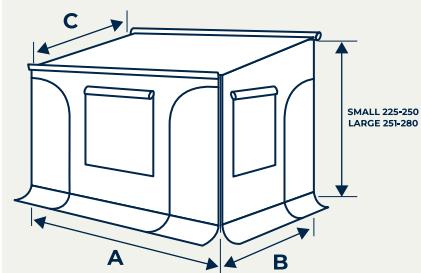

MODELLO	A - larghezza	B - profondità	C - estensione
300 Small (225-250)	275	230	250
350 Small (225-250)	325	230	250
400 Small (225-250)	375	230	250
450 Small (225-250)	425	230	250

MODELLO	A - larghezza	B - profondità	C - estensione
300 Large (251-280)	275	230	250
350 Large (251-280)	325	230	250
400 Large (251-280)	375	230	250
450 Large (251-280)	425	230	250



POLYESTER
240g/mq



26mm
ALUMINIUM
STRUCTURE



DARKENING
COVER

VERANDE

CARAVAN/AUTOCARAVAN

Living Room MIRAGE



Living Room MIRAGE



CARATTERISTICHE TECNICHE

Chiusura per tendalini per camper, adattabile alla maggior parte dei modelli Fiamma, Omnistore/Thule e Dometic.

Si compone di tre porte, una frontale affiancata da due finestre in cristallo ed oscurante esterno, e due laterali affiancate da una finestra con zanzariera e oscurante.

TECHNICAL FEATURES:

Screen room for camper awning, fitting all main models of brands Fiamma, Omnistore/Thule, Dometic. Three doors, a frontal one and two side ones.

Two crystal front windows with outside blind and two side windows with mosquito-net and outside blind

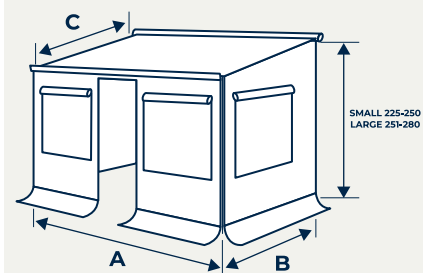

MODELLO	A - larghezza	B - profondità	C - estensione
300 Small (225-250)	275	230	250
350 Small (225-250)	325	230	250
400 Small (225-250)	375	230	250
450 Small (225-250)	425	230	250

MODELLO	A - larghezza	B - profondità	C - estensione
300 Large (251-280)	275	230	250
350 Large (251-280)	325	230	250
400 Large (251-280)	375	230	250
450 Large (251-280)	425	230	250



POLYESTER
240g/mq



26mm
ALUMINIUM
STRUCTURE



DARKENING
COVER

SUNSHADE

CARATTERISTICHE TECNICHE

Chiusura frontale applicabile alla maggior parte dei tendalini Fiamma, Omnistore/Thule e Dometic.
 Dotato di due ampie finestre in cristal per una migliore illuminazione, già dotate di predisposizione per le tendine.
 Applicabile tramite il cavetto al frontale dei tendalini.
 • TENDE NON INCLUSE

TECHNICAL FEATURES:

Front wall designed to fit most part of awnings Fiamma and Omnistore/Thule, Dometic.
 It comes equipped with two wide crystal windows for a better lighting. Curtains set-up included.
 Attachable by cable to the front of the awning.
 • CURTAINS NOT INCLUDED



COPERTURE

caravan/autocaravan

MODELLO	MISURA
300	230
350	230
400	230
450	230

SET TENDINE 4 PZ.



TENDINE
OPTIONAL

WING

CARATTERISTICHE TECNICHE

Chiusura laterale applicabile alla maggior parte dei tendalini Fiamma, Omnistore/Thule e Dometic.

Dotata di ampia finestra in cristallo con predisposizione per le tendine compresa. La chiusura Wing si può avere sia per il lato destro che per il lato sinistro, così da poter avere una chiusura su entrambi i lati contemporaneamente.

I laterali sono acquistabili singolarmente.

- Dimensioni (cm): A: 195 cm frontale - 240 cm posteriore
- TENDE NON INCLUSE

TECHNICAL FEATURES:

Side wall designed to fit most part of awnings Fiamma, Omnistore/Thule and Dometic.

Wing is equipped with a big window with curtain set-up included.

Side walls Wing can be assembled on the right side and on the left side at same time.

Wings are sold individually. It is not necessary to buy them in a set of two pieces.

- Dimensions (cm): A: 195 cm frontal - 240 cm rear
- CURTAINS NOT INCLUDED



MODELLO

MISURA

195 -240 CM

SET TENDINE 2 PZ.

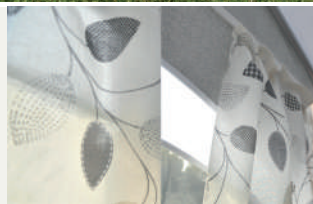

TENDINE
OPTIONAL



MADE IN ITALY

Screen

tessuto



CARATTERISTICHE TECNICHE

Parete in tessuto poliestere 100%, impermeabile, per una maggiore riservatezza nei periodi di sosta. Adattabile a tutti i tendalini con guida frontale e dotato di corde e picchetti per il montaggio. Disponibile in grigio.

TECHNICAL FEATURES:

100% waterproof polyester wall, provides a private area during a stop. Adaptable to all awnings with frontal rail, it is equipped with ropes and pegs. Available in grey.

MISURA

- 2.5 x 1.5 mt
- 3.0 x 1.5 mt
- 3.5 x 1.5 mt
- 4.0 x 1.5 mt
- 4.5 x 1.5 mt



POLYESTER



MADE IN ITALY

Screen

ombreggiante



CARATTERISTICHE TECNICHE

Pratica parete in tessuto OMBREGGIANTE poliestere spalmato PVC, offre una migliore riservatezza durante la sosta e un riparo dal sole. Dotato di corde e picchetti per il montaggio. Adattabile a tutti i tipi di tendalini con guida frontale. Disponibile in bianco.

TECHNICAL FEATURES:

It's a coated PVC mesh wall and it offers privacy during the break and a shelter from the sun. It comes with ropes and pegs and it's suitable for Freedom and all the other awnings with frontal rail. Available in white.

MISURA

- 2.5 x 1.5 mt
- 3.0 x 1.5 mt
- 3.5 x 1.5 mt
- 4.0 x 1.5 mt- 4.5 x 1.5 mt



TEXTILENE



MADE IN ITALY

Defender



CARATTERISTICHE TECNICHE

Coppia di pareti laterali in poliestere 100% di facile montaggio e pratico utilizzo che consente di proteggersi dal sole. Dotati di paleria in alluminio.

TECHNICAL FEATURES:

Polyester100% twin sidewalls is easy and fast to assemble; it offers an immediate sun protection.

MISURA

A: 265 - B: 235 - C: 215

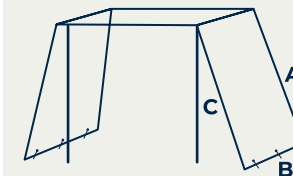

26mm ALUMINIUM STRUCTURE



POLYESTER





VERANDE - TENDE - TENDE CUCINA - GAZEBO - SEDIE E TAVOLI - MOBILETTI - ACCESSORI - VERANDE AUTOCARAVAN - ACCESSORI VERANDE E CARAVAN



www.convertende.it